

EVAPORATIVE CONDENSERS

Bulletin 170A

eco-ATC-H HYBRID



Available with Optional
evapco
WATER SYSTEMS

ENGINEERED FOR OPTIMAL WET AND DRY PERFORMANCE



IARW International Association of Refrigerated Warehouses

Member of
iiar
International Institute of Ammonia Refrigeration
www.iiar.org

MEMBER OF
AIRI
Air-Conditioning, Heating, and Refrigeration Institute

eco-ATC-H Design & Construction Features

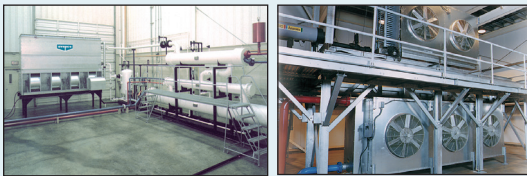

About EVAPCO

Evapco is the global innovator in heat transfer solutions. Our pledge is to make everyday life easier, more comfortable, more reliable, and more sustainable for people everywhere. With manufacturing facilities and sales offices in more than 50 countries and 48 active US patents—we are the team that engineers and contractors know they can count on for life.

Contact

your local Evapco Representative
or visit evapco.com to learn more.

Evolution of Heat Transfer Technology

EVAPCO has a long standing commitment to heat transfer research and development. This commitment has resulted in a number of advancements in heat transfer coil design. Up until the mid-1980's, evaporative condensers were manufactured with tightly packed round tube coils. Through thousands of hours of testing and research, EVAPCO developed the Thermal Pak® coil. The Thermal Pak® coil was patented in 1987, (now expired), and changed the thinking of system design engineers by changing the shape of the coil tubes. The elliptical tube design maximized the effective tube surface area while lowering airside pressure drop and allowing for higher water loading. The combination of the elliptical shape tube in the Thermal Pak® orientation increased heat transfer efficiency and resulted in one of the highest capacities per plan area of evaporative condensers available today.

Throughout the late 1980's and into the 1990's EVAPCO was continuously looking for ways to improve heat transfer efficiency. This research resulted in the development of the Thermal Pak® II heat transfer coil. The Thermal Pak® II coil utilized the same elliptical shape tube introduced in the original Thermal Pak coil, but changed the orientation of the tubes to improve the tubes air to water interface for increased heat transfer efficiency.

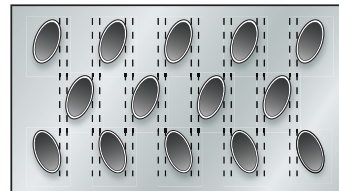

Thermal-Pak® II Coil by EVAPCO

Research and development is an on-going process at EVAPCO. Through the success of the Thermal Pak II coil, EVAPCO saw the potential for new coil configurations and the need for new manufacturing technology to improve processes and efficiency. During this same time, it became evident that a need exists for more environmentally conscious cooling products.

The combination of EVAPCO's R&D, manufacturing and environmental commitment has resulted in the development of **Ellipti-fin®** Coil Heat Transfer Technology.

The **Ellipti-fin®** coil utilizes elliptical shape tube with extended surface fins for maximum heat transfer efficiency. **The extended surface increases the heat transfer efficiency in the evaporative or wet mode as well as the dry mode of operation.**

eco-ATC-H Design & Construction Features

eco-ATC-H Dry Performance Powered by Innovative Coil Technology

Ellipti-fin® Heat Transfer Coil

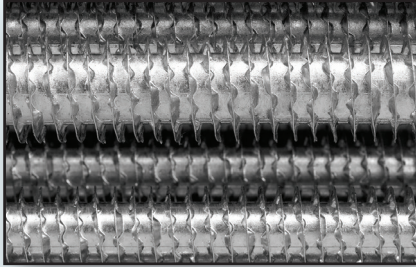

- Elliptical Tubes with Spiral Wound Fins
- Improved Dry and Wet Operation
- All Rows Finned
- Hot-Dip Galvanized Steel
- Nitrogen Charged Before Shipment

ARID fin Pak™ Dry Cooling Coil

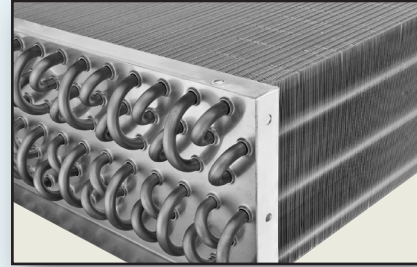

- Superior Dry Heat Transfer
- 5/8" Type 304L Stainless Steel Tubes
- Marine Grade Aluminum Fins
- Hydraulically Expanded
- Nitrogen Charged Before Shipment

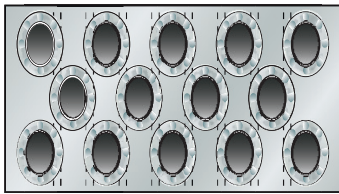

Ellipti-fin® Finned Elliptical Tube by EVAPCO

The **Ellipti-fin**® coil incorporates features of both the Thermal Pak and Thermal Pak II coils as the tubes are oriented vertically yet spaced so as not to increase the airside pressure drop. As such, eco-ATC-H condensers are not subject to the performance penalties normally associated with round tube extended surface coils.

Ellipti-fin® coils are manufactured from high quality carbon steel tubing following the most stringent quality control procedures and in accordance with the ASME B31.5 Refrigerant Piping Code. Each circuit is inspected to assure the material quality and tested before fins are wound onto the surface of the tube. Each circuit is then assembled into a complete coil with a design pressure of 300 psig (optional design pressure of 400 psig is available). Finally the assembled coil is strength tested in accordance with ASME B31.5 and subsequently leak tested using air under water. To protect the coil against corrosion, and complete the bond between tube and fin, the entire assembly is dipped in molten zinc (hot dip galvanized) at a temperature of approximately 800°F.

The **Ellipti-fin**® coil design utilizes counterflow heat transfer. The rows of the finned elliptical tubes are positioned vertically in the direction of airflow to enhance turbulence, which increases heat transfer while minimizing airside pressure drop. The design features of EVAPCO's **Ellipti-fin**® condensing coils ensure the end-user will receive maximized evaporative heat transfer efficiency wet or dry.

ARID fin Pak™ Dry Cooling Coil

ARID fin Pak™ Dry Cooling Coils are constructed with 5/8" diameter type 304L stainless steel tubing and marine-grade aluminum fins. The stainless steel tubing meets the requirements of ASME B31.5 refrigerant piping code. The standard **ARID fin Pak**™ Dry Cooling Coils are designed with a fin density of 10 fins per inch for maximum heat transfer efficiency in the smallest plan area. Optional fin densities are available (Consult the factory for selections and pricing).

The SST 304L round tubes are fit into the aluminum fin plate and hydraulically expanded. EVAPCO's precisely controlled hydraulic expansion process results in more consistent contact between the tube and fin plate than conventional mechanical expansion methods. The **ARID fin Pak**™ dry cooling coil has a design pressure of 300 psig (optional design pressure of 400 psig is available) and is strength tested in accordance with ASME B31.5 and nitrogen charged prior to shipment.

eco-ATC-H Design & Construction Features

The eco-ATC-H line of evaporative condensers represents EVAPCO's newest advancement in thermal heat transfer research and development. Utilizing the **ARID finPak™** heat transfer coil, the eco-ATC-H offers improved heat transfer during dry operation and significant water savings due to extended periods of dry operation. The eco-ATC-H is the latest example in EVAPCO's on-going commitment to quality, environmentally friendly products.



PVC Spray Distribution Header with ZM®II Nozzles

- Large orifice nozzles prevent clogging (no moving parts).
- Redesigned nozzles for superior water distribution.
- Nozzles are threaded into header at proper orientation.
- Fixed position nozzles require zero maintenance.
- Threaded end caps for ease of cleaning.
- Guaranteed for life.

Self Supporting Service Platforms (Optional)

- Dual platform arrangement provides access to wet/dry coils and drive system.
- Includes access ladders - field installed.

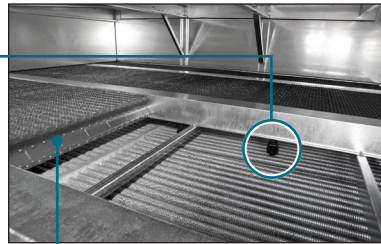

Water Saver Drift Eliminators

- Patented design reduces drift rate to 0.001%.
- Made from corrosion resistant PVC for long life.
- Prevents water droplets from contacting Arid-fin Pak™ coil.

U.S. Patent No. 6,315,804

Air Inlet Access Door (Optional)

- Increased ease of access to basin.
- Hinged access panel with quick release mechanism.
- Not available on all models.



WST Framed Inlet Louvers (Water and Sight Tight)

- Framed for easy handling, tighter fit and longer life
- Design keeps sunlight out – preventing biological growth.
- Keeps water in while keeping dirt and debris out.

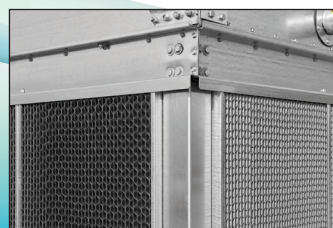

"Clean Pan" Basin Design

- Access from all four sides.
- Large open area simplifies maintenance.
- Basin may be inspected with pumps running.
- Sloped basin design prevents sediment buildup, biological film and standing water.



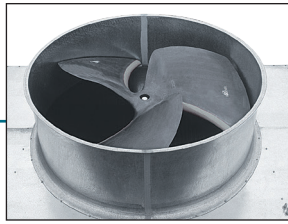

Super Low Sound Fan (Optional)

- 9-15 dB(A) sound reduction.
- Extremely wide chord fan blades for sound sensitive applications.
- One piece molded heavy duty construction.

Advanced Drive System Design

- Totally Enclosed Fan Motors assures Long Life.
- Power-Band Belts for Better Lateral Rigidity.
- Advanced Design Aluminum Fan Blades.
- Non-corroding Cast Aluminum Sheaves.
- Heavy-Duty Fan Shaft Bearings with L-10 Life of 75,000 - 135,000 hrs.
- All Other Components Corrosion Resistant Materials.
- All Components Covered by 5 Year Warranty.



ARID fin Pak™ Heat Transfer Technology

- Type 304L stainless steel tube/aluminum fin coil located above drift eliminators.
- Designed to operate in dry mode for an extended period.
- High heat transfer efficiency.

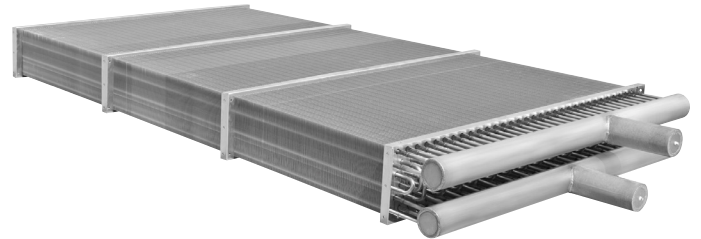

Ellipti-fin® Heat Transfer Technology

- Features EVAPCO's exclusive CROSScool™ tube enhancement for greater internal heat transfer.
 - Thermal Pak® coil with extended surface.
 - Water savings through extended periods of dry operation.
 - High heat transfer efficiency.
 - Low refrigerant charge.
- Patent Pending

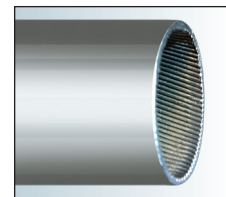

CROSScool™

Unique Field Seam

- Eliminates up to 66% of fasteners.
- Self guiding channels improve quality of field seam to reduce leaks.
- Easy to install.
- Lower installation cost.



Totally Enclosed Pump Motors

- Help assure long, trouble-free operation.



Non-Chemical Water Treatment (Optional)

- Scale, corrosion and bacteria control.
- Factory mounted with single source responsibility.
- Environmentally safe, chemical-free water treatment.

U.S. Patent No. 7,704,364



Solid Chemistry Water Treatment (Optional)

- Controlled release chemistry provides uniform treatment over a 30 day period.
 - Factory mounted and wired.
 - Easier and safer, eliminates the potential for liquid spills.
- U.S. Patent No. 8,398,850

eco-ATC-H Water Saving Technology

Engineered for Efficient Dry Performance to Meet Future Global Climate Change and Water Use Restrictions

Significant Water Savings

The **ARID fin Pak™** Dry Coil combined with EVAPCO's **Ellipti-fin®** coil technology enables the eco-ATC-H to be operated in a 100% Dry Mode at a significantly higher switchover temperature than that of a typical bare tube coil evaporative condenser. This leads to a much higher number of hours per year the condenser can operate in dry mode (spray pumps off), thus significantly reducing annual water consumption. This combination of heat transfer technologies makes the eco-ATC-H the most water efficient EVAPCO condenser.

Consider a meat processing plant application near Wichita, KS where a condenser is required to reject a constant heat load of approximately 7,500 MBH at a 95°F condensing temperature and a summer design wet bulb temperature of 78°F. The process operates 24 hours a day, five days a week.

The ATC-E evaporative condenser, the eco-ATC-A and the eco-ATC-H evaporative condenser are compared as follows:

Model Comparison

Model	ATC-791E	eco-ATC-761A	eco-ATC-H 12-2K24-U34
Plan Area	12' x 20'	12' x 20'	12' x 24'
Total Fan Motor	40 HP	40 HP	40 HP
Total Pump Motor	10 HP	10 HP	10 HP

Dry Operation Performance Comparison

Model No.	Design Capacity (MBH)	Dry Bulb Switch Point (°F) (% Design Capacity)		
		100%	75%	50%
ATC-791E	7910	-39.9	-6.2	27.5
eco-ATC-761A	7610	12.1	32.4	53
eco-ATC-H 12-2K24-U34	7520	38.7	52.5	66.5

eco-ATC-H Water Saving Technology

eco-ATC-H Water Saving Analysis

Utilizing the Water & Energy Savings Calculator in Spectrum™ with required key inputs:

Monthly Average Ambient Temperature
Wichita, KS

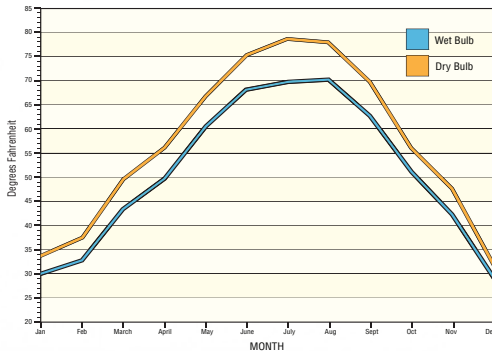

Load Profile: Meat Processing

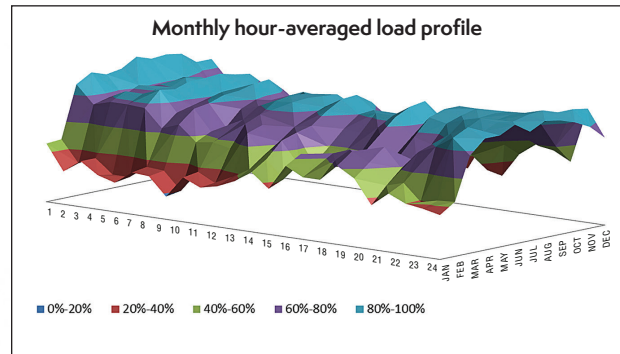

Weather Station: For Wichita, KS, the selected weather station is McConnell AFB
The Temperature Profile generated to estimate water and energy usage is based on 5 year weather data from the National Climatic Data Center (NCDC). The weather data shown above was collected from MC CONNELL AFB, USA
For more information visit: <http://www.ncdc.noaa.gov/oa/ncdc.html>

Meat Processing
Profile Provided Courtesy of Cascade Energy

Cycles of Concentration:..... Historical water analysis for Wichita, KS is on average 4 cycles
Profile Days: 5 Week Days, and 2 Weekend Days
Potable Water Cost for Wichita: Estimated at .0028 \$/gal
Waste Water Treatment Costs for Wichita: Estimated at .0031 \$/gal
Power Costs: Estimated at .0637 \$/kwh

Water and Energy Analysis*			
Selected Weather Station: McConnell AFB		Load Profile: Beef	
Condensing Temperature: 95°F		Week Days: 5	
Wet Bulb Temperature: 78°F		Weekend Days: 2	
Refrigerant: NH3		Cycle of Concentration: 4	
Model Number:	ATC-791E	eco-ATC-761A	eco-ATC-H 12-2K24-U34
Quantity:	1.00	1.00	1.00
Dry Bulb Switchover(°F)	-39.9	12.1	38.7
Total Estimated Water Usage per year (gal.)	4,616,650	4,008,150	3,360,490
Total Estimated Water Cost per year (USD)	16,490	14,320	12,000
Total Estimated Energy Usage per year (kWh)	92,780	87,490	58,310
Total Estimated Energy Cost per year (USD)	5,910	5,570	3,720
Total Estimated Utility Operating Cost	\$22,400	\$19,890	\$15,716

*Water and energy use and costs are estimates only and are provided for the purpose of comparing the performance of evaporative condensers. Actual water/energy usage and costs will vary depending on weather, load profile, cycles of concentration and the control logic used to optimize system performance. Also, power, water and sewer costs are subject to local rates. The water and energy usage is calculated assuming a fixed condensing temperature and the use of variable frequency drives. Projected energy use is for evaporative condensers only, NOT total refrigeration system energy use. The Temperature Profile generated to estimate water and energy usage is based on 5 Year weather data from the National Climatic Data Center (NCDC). Load profiles utilized in the program are based on industrial refrigeration applications and have been provided courtesy of Cascade Energy- Portland, OR.

eco-ATC-H Design Features

eco-ATC-H Dry Performance Powered by Innovative Coil Technology

Principle of Operation

Evaporative (Wet) Mode – Spray Pump(s) Energized

The refrigerant gas is discharged from the compressor into the inlet of the **ARID *fin Pak*™ Dry Coil** which is positioned in the discharge air stream above the unit's drift eliminators and below the fan section. Ambient air is drawn into the unit, by the condenser's fans, through inlet louvers located in the lower section above the water basin. The air is drawn upward through the wet coil into the drift eliminators (which remove entrained water droplets from the air stream) and into the **ARID *fin Pak*™ Dry Coil**. Heat from the refrigerant gas is transferred to the air as it comes into contact with the tubes and densely packed fins of the **ARID *fin Pak*™ Dry Coil**. The refrigerant gas exits the **ARID *fin Pak*™ Dry Coil** and travels via inter-connecting piping (by others) to the inlet of the **Ellipti-*fin*® Coil** located in the lower section of the eco-ATC-H Condenser. Water from the condenser's sump is circulated over the wet coil as the ambient air is simultaneously drawn into the unit and travels up through the **Ellipti-*fin*®**. A portion of the spray water is evaporated into the air stream as it travels through the wet coil. This evaporative process cools the spray water, which in turn cools the coil tubes and extended surface fins. The cool tube walls and extended surface fins cause the refrigerant gas to give up heat and condense into a liquid. The condensed liquid flows out of the **Ellipti-*fin*®** to the high pressure receiver for return to the system. The water which has not evaporated falls into the sump and is recirculated by the spray pump to the water distribution system located above the **Ellipti-*fin*®**.

The amount of water consumed during this mode of operation is a function of the amount of heat rejected. Water consumption includes the volume of water which is evaporated during the cooling process and the amount of water which is discharged (referred to as "blow-down") to maintain the required cycles of concentration in order to meet water quality guidelines.

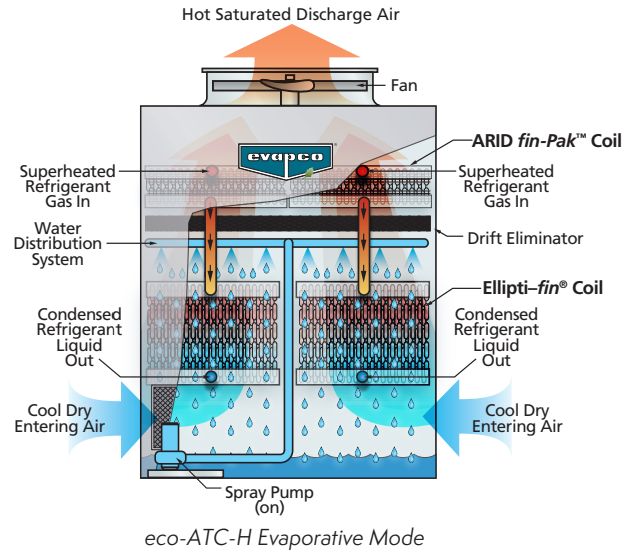

Dry Mode – Spray Pump De-energized

The refrigerant gas is discharged from the compressor into the inlet of the **ARID *fin Pak*™ Dry Coil** which is positioned in the dry air stream above the unit's drift eliminators and below the fan section. Ambient air is drawn into the unit by the condenser's fans, through inlet louvers located in the lower section above the water basin. The air is drawn upward through the **Ellipti-*fin*®** into the **ARID *fin Pak*™ Dry Coil** above. Heat from the refrigerant gas is transferred to the air as it comes into contact with the tubes and densely packed fins of the **ARID *fin Pak*™ Dry Coil**. The refrigerant gas exits the **ARID *fin Pak*™ Dry Coil** and travels via the inter-connecting piping to the inlet of the **Ellipti-*fin*®**. The ambient air entering the unit travels upward through the **Ellipti-*fin*® Coil** which in turn cools the coil tubes and extended surface fins. The cool tube walls and extended surface fins cause the refrigerant gas to give up heat and condense into a liquid. The condensed liquid flows out of the **Ellipti-*fin*®** to the high pressure receiver for return to the system.

There is **NO WATER** consumed during this mode of operation.

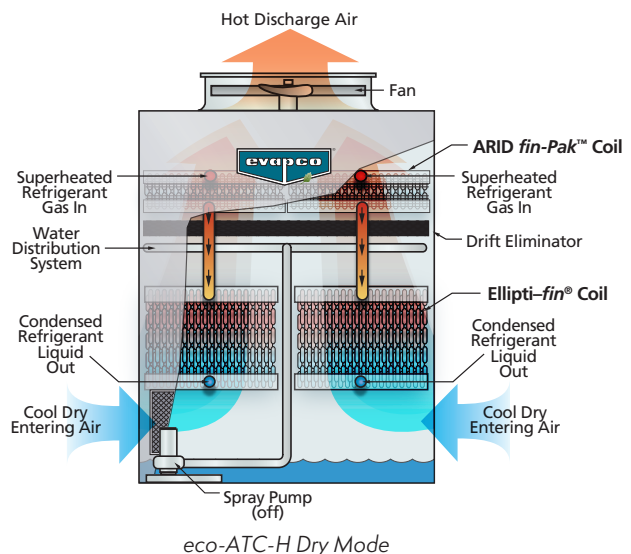

eco-ATC-H Design Features

Construction Features

EVAPCO, long known for using premium materials of construction, has developed the ultimate system for corrosion protection in galvanized steel construction – the EVAPCOAT Corrosion Protection System. Marrying corrosion free materials with heavy gauge mill hot-dip galvanized steel construction to provide the longest life product with the best value.

G-235 Mill Hot-Dip Galvanized Steel Construction

Mill hot-dip galvanized steel has been successfully used for over 40 years for the protection of evaporative condensers against corrosion. There are various grades of mill galvanized steel each with differing amounts of zinc protection. EVAPCO has been a leader in the industry in developing heavier galvanizing, and was the first to standardize on G-235 mill hot-dip galvanized steel.

G-235 designation means there is a minimum of 2.35 ounces of zinc per square foot of surface area as measured in a triple spot test. G-235 is the heaviest level of galvanizing available for manufacturing evaporative condensers and has a minimum of 12% more zinc protection than competitive designs using G-210 steel.

During fabrication, all panel edges are coated with a 95% pure zinc-rich compound for extended corrosion resistance.

Type 304 Stainless Steel Strainers

Subjected to excessive wear and corrosion, the sump strainer is critical to the successful operation of the condenser. EVAPCO uses only stainless steel for this very important component.

Unique Seam Design—Eliminate Field Leaks

The eco-ATC-H features EVAPCO's unique panel construction design which includes a special butyl tape sealer. Each joint is then backed with a secondary caulking compound and encased in a double-brake flange for added strength and structural integrity. This unique sealing system has been proven effective in both laboratory tests and years of field application.

Easy Field Assembly

The eco-ATC-H features a unique field seam design which ensures easier assembly and fewer field seam leaks. The field seam incorporates self-guiding channels to guide the coil casing section into position and set in place on the bottom basin section of the condenser. In addition, the design eliminates up to 66% of the fasteners typically used to join the condenser sections in the field significantly reducing the contractor labor costs for installation.

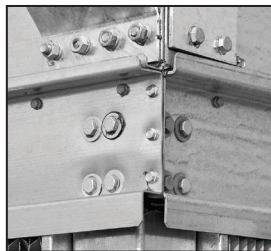

Improved Maintenance

ZM® II Spray Nozzle Water Distribution System

Even and constant water distribution is paramount for reliable, scale-free evaporative condensing. EVAPCO'S Zero Maintenance ZM® II Spray Nozzle remains clog-free under the toughest conditions to deliver approximately 6 GPM to every square foot of coil plan area.

The heavy-duty ABS ZM® II Spray Nozzles have a 1-1/4" diameter opening and a 1-1/4" splash plate clearance. The fixed position ZM® II Spray Nozzles are mounted in corrosion-free PVC water distribution pipes that have threaded end caps. Together, these elements combine to provide enhanced water droplet formation, delivered uniformly over the coil resulting in superior thermal performance and a virtually maintenance free water distribution system.



ZM® II Nozzle

Alternate Materials of Construction

EVAPCO induced draft condensers have a modular design which allows for specific areas to be enhanced for increased corrosion protection. For particularly corrosive environments, EVAPCO condensers are available with Stainless Steel construction for the basin, casing and/or coil.

Stainless Steel Basin

In addition to the EVAPCOAT Corrosion Protection System, EVAPCO offers optional Type 304 or Type 316 stainless steel construction for superior corrosion resistance. EVAPCO induced draft condensers have a modular design which allows for specific areas to be enhanced for increased corrosion protection. The basin area of a condenser is often subjected to high concentrations of impurities and silt. EVAPCO's stainless steel basin option includes welded seam construction as standard. For particularly corrosive environments, stainless steel construction is also available for the coil casing / fan section.

"Clean Pan" Basin Design

EVAPCO eco-ATC-H condensers feature a sloped basin from the upper to lower pan section. This "Clean Pan" design allows the water to be completely drained from the basin. The condenser water will drain from the upper section to the depressed lower pan section where the dirt and debris can be easily flushed out through the drain. This design helps prevent

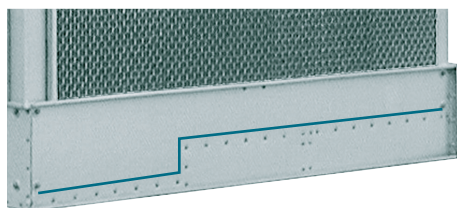

buildup of sedimentary deposits, biological films and minimizes standing water.

eco-ATC-H Design Features

Belt Drive Units—8-1/2' & 17' Wide Models

The fan motor and drive assembly are designed to allow easy servicing of the motor and adjustment of the belt tension from the exterior of the unit. A TEFC fan motor is mounted on the outside of these models. A protective cover swings away to allow servicing and belt adjustment. A large hinged access door with a "quick release" latch provides access to the fan section for maintenance.



External Motor Mount
(with optional ladder)

Belt Drive Units—10', 12' & 24' Wide Models

The fan motor and drive assembly are designed to allow easy servicing of the motor and adjustment of the belt tension from the exterior of the unit. The TEAO fan motor is located inside the fan casing on a rugged heavy duty motor base. The innovative motor base also features a unique locking mechanism for a positive adjustment.

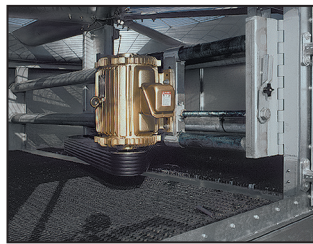

Motor Base Assembly

The motor base is designed to swing out through a very large, 14 square foot access opening. This allows for easy servicing of the motor.

Drive System

Inverter Duty Motors: Inverter Duty Motors are standard on eco-ATC-H condensers. Inverter Duty motors are totally enclosed premium efficiency and inverter capable (VFD by others).

Note: Variable Frequency Drive control may require other component modification such as motor shaft grounding brushes, AC load reactors, low pass filters and tuned trap filters to ensure proper motor performance and service life.

Power- Band Drive Belt: The Power-Band is a solid-back, multigroove belt system that has high lateral rigidity. The proven drive system is used on 8' wide and wider models. The belt is constructed of neoprene with polyester cords. The drive belt is designed for minimum 150% of the motor nameplate horsepower for long life and durability.

Fan Shaft Bearings: The fan shaft bearings in eco-ATC-H units are specially selected for long, trouble-free life. They are rated for an L-10 life of 75,000 to 135,000 hours and are the heaviest pillow block bearing available.

Aluminum Alloy Sheaves: Fan sheaves are constructed of corrosion free aluminum for long life, eliminating the corrosion that occurs on cast steel sheaves, thereby extending belt life.

Five Year Drive Warranty: All drive components on eco-ATC-H units are covered by EVAPCO's exclusive 5 year drive warranty - including fan motors and belts!

Superior Water Saver Drift Eliminators

An extremely efficient drift eliminator system is standard on EVAPCO condensers. The patented system removes entrained water droplets from the air stream to limit the drift rate to less than 0.001% of the recirculating water rate. The drift eliminators are constructed of an inert polyvinyl chloride (PVC) plastic material which effectively eliminates corrosion of these vital components. They are assembled in sections to facilitate easy removal for inspection of the water distribution system.



Water Saver Drift Eliminator

Superior WST Framed Air Inlet Louver Design

EVAPCO'S WST Framed Inlet Louvers keep water in and sunlight out of the basins of induced draft products. The unique non-planar design is made from light-weight PVC sections which easily fit together and have no loose hardware, enabling easy basin access. U.S. Patent 7,927,196



Framed Inlet Louver Design

Developed with computational fluid dynamics (CFD) software and tested in EVAPCO's R&D center, the louver's air channels are optimized to maintain fluid dynamic and thermodynamic efficiency and block all line-of-sight paths into the basin eliminating splash-out; even when the fans are off. Additionally, algae growth is minimized by blocking all sunlight.

The combination of rugged frames, easy basin access, no splash-out and minimized algae growth saves the end user money on maintenance hours, water consumption and water treatment costs.

Air Inlet Access Door (Optional)

To aid in basin maintenance, eco-ATC-H models can be equipped with an optional air inlet access door. This feature improves the maintainability of the condenser by allowing easy access to the make-up float assembly and strainer for inspection without removing an entire inlet louver.

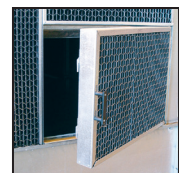

Engineering Dimensions & Data

eco-ATC-H 9-2H9-U22 to eco-ATC-H 9-4K9-U34

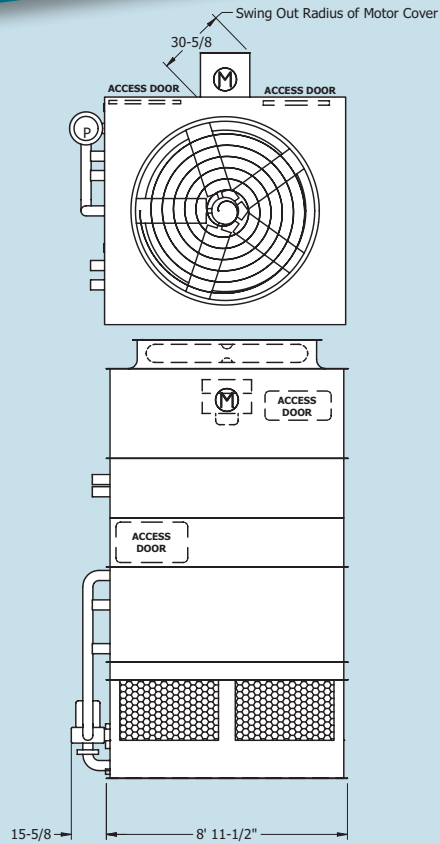
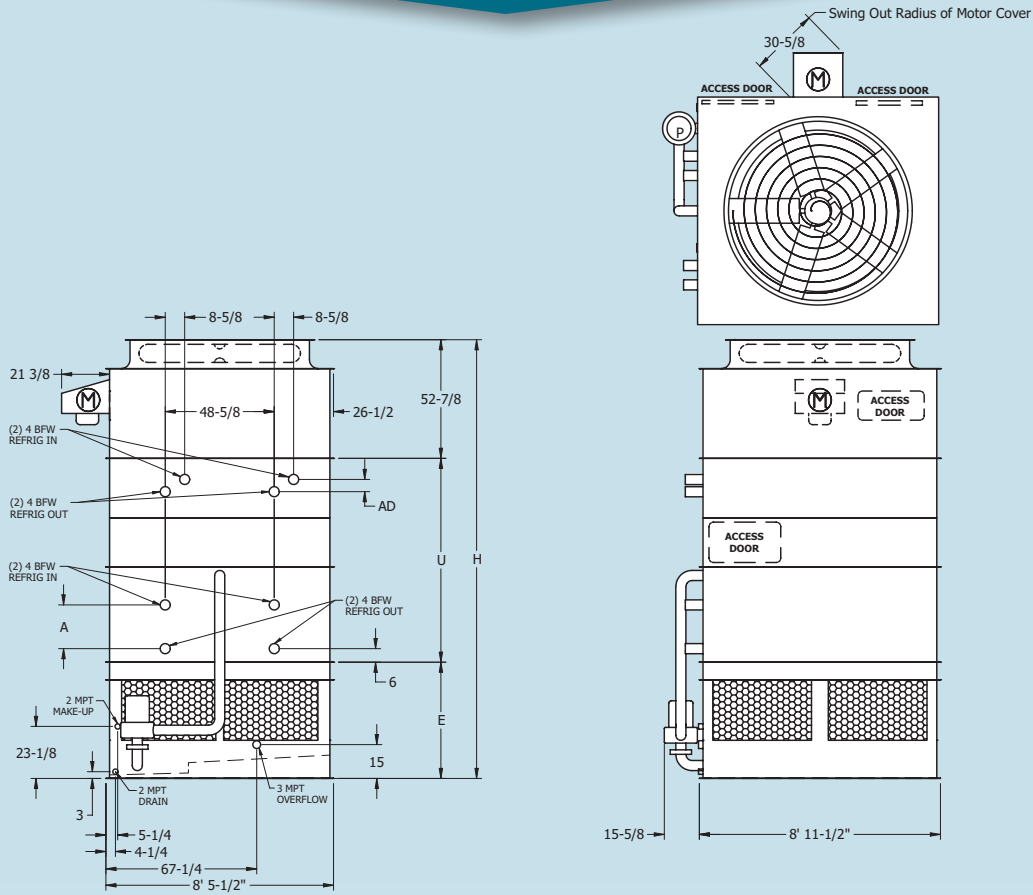

Table 1 Engineering Data

Model No.	R-717 Tons*		Fans		Weights†			Coil Volume (ft.)	NH3 Op. Charge (lbs.)	Spray Pump		Remote Sump		Dimensions (ft)			Dimensions (in)		
	Wet Capacity	Dry Capacity @ 50°F DB Switch Point	HP	CFM	Shipping	Heaviest Section†	Operating			HP	GPM	Gallons Req'd**	Conn. Size	Operating Weight (lbs)	Height H	Lower E	Middle U	Wet Coil A	Dry Coil AD
eco-ATC-H 9-2H9-U22	131	97	7.5	34,900	10,360	6,950	12,880	18	123	2	410	250	8"	11,600	15' 8"	4' 3-7/8"	6' 11-1/8"	12"	5-1/2"
eco-ATC-H 9-2H9-U34	132	105	7.5	33,900	10,800	7,400	13,330	20	129	2	410	250	8"	12,050	15' 8"	4' 3-7/8"	6' 11-1/8"	12"	6-7/8"
eco-ATC-H 9-2I9-U22	140	103	10	37,900	10,370	6,950	12,890	18	123	2	410	250	8"	11,610	15' 8"	4' 3-7/8"	6' 11-1/8"	12"	5-1/2"
eco-ATC-H 9-2I9-U34	140	112	10	36,700	10,810	7,400	13,340	20	129	2	410	250	8"	12,060	15' 8"	4' 3-7/8"	6' 11-1/8"	12"	6-7/8"
eco-ATC-H 9-2I9-U22	153	111	15	41,800	10,500	6,950	13,020	18	123	2	410	250	8"	11,740	15' 8"	4' 3-7/8"	6' 11-1/8"	12"	5-1/2"
eco-ATC-H 9-2I9-U34	152	122	15	40,300	10,940	7,400	13,470	20	129	2	410	250	8"	12,190	15' 8"	4' 3-7/8"	6' 11-1/8"	12"	6-7/8"
eco-ATC-H 9-2K9-U22	162	116	20	44,600	10,560	6,950	13,080	18	123	2	410	250	8"	11,800	15' 8"	4' 3-7/8"	6' 11-1/8"	12"	5-1/2"
eco-ATC-H 9-2K9-U34	162	128	20	43,000	11,000	7,400	13,530	20	129	2	410	250	8"	12,250	15' 8"	4' 3-7/8"	6' 11-1/8"	12"	6-7/8"
eco-ATC-H 9-3H9-U22	155	103	7.5	34,700	11,960	8,550	14,530	25	172	2	410	250	8"	13,250	16' 3-1/2"	4' 3-7/8"	7' 6-5/8"	19-1/2"	5-1/2"
eco-ATC-H 9-3H9-U34	154	108	7.5	33,800	12,400	9,000	14,980	27	178	2	410	250	8"	13,700	16' 3-1/2"	4' 3-7/8"	7' 6-5/8"	19-1/2"	6-7/8"
eco-ATC-H 9-3I9-U22	165	110	10	37,700	11,970	8,550	14,540	25	172	2	410	250	8"	13,260	16' 3-1/2"	4' 3-7/8"	7' 6-5/8"	19-1/2"	5-1/2"
eco-ATC-H 9-3I9-U34	165	116	10	36,700	12,410	9,000	14,990	27	178	2	410	250	8"	13,710	16' 3-1/2"	4' 3-7/8"	7' 6-5/8"	19-1/2"	6-7/8"
eco-ATC-H 9-3I9-U22	181	119	15	41,700	12,100	8,550	14,670	25	172	2	410	250	8"	13,390	16' 3-1/2"	4' 3-7/8"	7' 6-5/8"	19-1/2"	5-1/2"
eco-ATC-H 9-3I9-U34	180	126	15	40,500	12,540	9,000	15,120	27	178	2	410	250	8"	13,840	16' 3-1/2"	4' 3-7/8"	7' 6-5/8"	19-1/2"	6-7/8"
eco-ATC-H 9-3K9-U22	192	125	20	44,700	12,160	8,550	14,730	25	172	2	410	250	8"	13,450	16' 3-1/2"	4' 3-7/8"	7' 6-5/8"	19-1/2"	5-1/2"
eco-ATC-H 9-3K9-U34	191	133	20	43,200	12,600	9,000	15,180	27	178	2	410	250	8"	13,900	16' 3-1/2"	4' 3-7/8"	7' 6-5/8"	19-1/2"	6-7/8"
eco-ATC-H 9-4H9-U22	172	106	7.5	34,300	13,570	10,160	16,190	32	221	2	410	250	8"	14,910	16' 11"	4' 3-7/8"	8' 2-1/8"	27"	5-1/2"
eco-ATC-H 9-4H9-U34	171	109	7.5	33,500	14,010	10,610	16,640	33	227	2	410	250	8"	15,360	16' 11"	4' 3-7/8"	8' 2-1/8"	27"	6-7/8"
eco-ATC-H 9-4I9-U22	184	114	10	37,300	13,580	10,160	16,200	32	221	2	410	250	8"	14,920	16' 11"	4' 3-7/8"	8' 2-1/8"	27"	5-1/2"
eco-ATC-H 9-4I9-U34	183	117	10	36,400	14,020	10,610	16,650	33	227	2	410	250	8"	15,370	16' 11"	4' 3-7/8"	8' 2-1/8"	27"	6-7/8"
eco-ATC-H 9-4I9-U22	201	124	15	41,400	13,710	10,160	16,330	32	221	2	410	250	8"	15,050	16' 11"	4' 3-7/8"	8' 2-1/8"	27"	5-1/2"
eco-ATC-H 9-4I9-U34	200	128	15	40,200	14,150	10,610	16,780	33	227	2	410	250	8"	15,500	16' 11"	4' 3-7/8"	8' 2-1/8"	27"	6-7/8"
eco-ATC-H 9-4K9-U22	215	131	20	44,300	13,770	10,160	16,390	32	221	2	410	250	8"	15,110	16' 11"	4' 3-7/8"	8' 2-1/8"	27"	5-1/2"
eco-ATC-H 9-4K9-U34	213	136	20	43,000	14,210	10,610	16,840	33	227	2	410	250	8"	15,560	16' 11"	4' 3-7/8"	8' 2-1/8"	27"	6-7/8"

* Tons at standard conditions: 96.3°F condensing, 20°F suction and 78°F W.B.

** Gallons shown is water in suspension in unit and piping. Allow for additional water in bottom of remote sump to cover pump suction and strainer during operation. (12" would normally be sufficient.)

† Heaviest section is the coil section.

Dimensions are subject to change. Do not use for pre-fabrication. Quantity of coil connections subject to change based on refrigerant and design conditions.

NOTE: Interconnecting piping between ARID *fin Pak*™ Dry Coil outlets and Ellipti-*fin*® Coil inlets are field installed and tested (by others).

Engineering Dimensions & Data

eco-ATC-H 9-2114-U22 to eco-ATC-H 9-4M14-U34

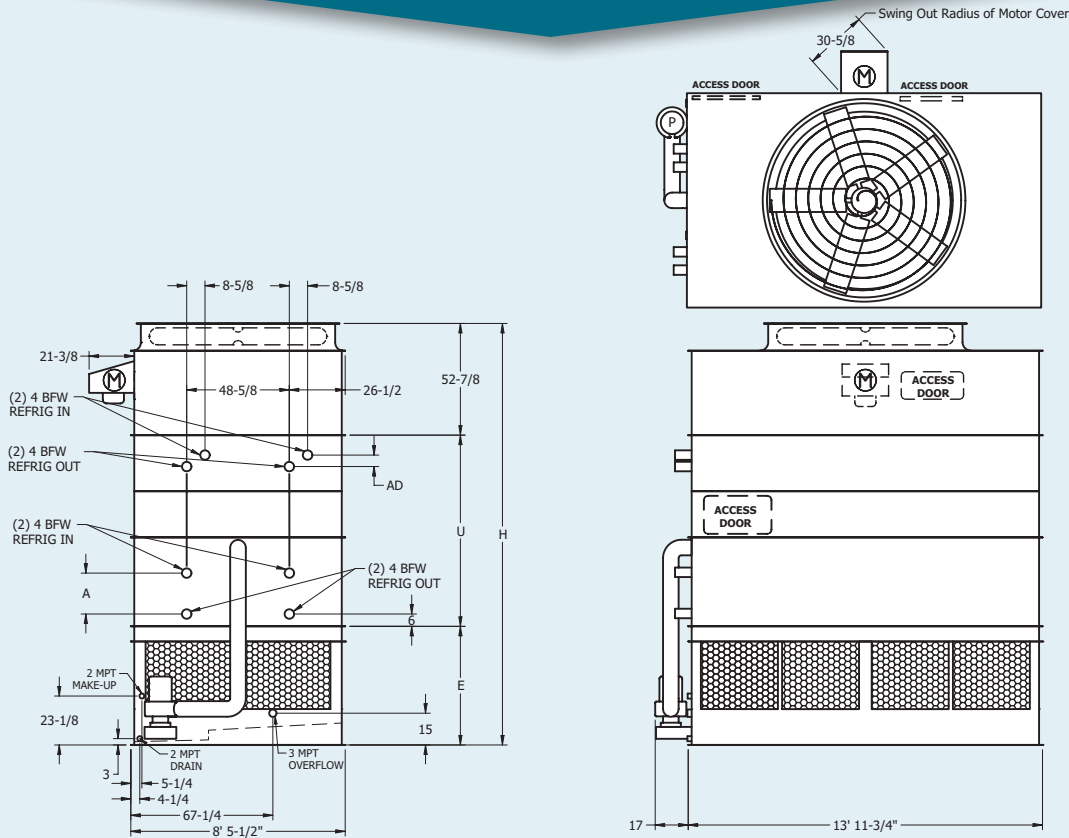

Table 3 Engineering Data

Model No.	R-717 Tons [*]		Fans		Weights [†]			Coil Volume (ft.)	NH ₃ Op. Charge (lbs.)	Spray Pump		Remote Sump			Dimensions (ft)			Dimensions (in)	
	Wet Capacity	Dry Capacity @ 50°F DB Switch Point	HP	CFM	Shipping	Heaviest Section [†]	Operating			HP	GPM	Gallons Req'd ^{**}	Conn. Size	Operating Weight (lbs)	Height H	Lower E	Middle U	Wet Coil A	Dry Coil AD
eco-ATC-H 9-2114-U22	200	148	10	52,500	14,350	9,840	18,430	28	186	5	650	380	10"	16,470	16'3/8"	4'8-1/4"	6'11-1/8"	12"	5-1/2"
eco-ATC-H 9-2114-U34	200	161	10	51,200	15,060	10,550	19,140	30	194	5	650	380	10"	17,180	16'3/8"	4'8-1/4"	6'11-1/8"	12"	6-7/8"
eco-ATC-H 9-2114-U22	218	162	15	59,000	14,480	9,840	18,560	28	186	5	650	380	10"	16,600	16'3/8"	4'8-1/4"	6'11-1/8"	12"	5-1/2"
eco-ATC-H 9-2114-U34	219	177	15	57,300	15,190	10,550	19,270	30	194	5	650	380	10"	17,310	16'3/8"	4'8-1/4"	6'11-1/8"	12"	6-7/8"
eco-ATC-H 9-2K14-U22	233	171	20	63,500	14,540	9,840	18,620	28	186	5	650	380	10"	16,660	16'3/8"	4'8-1/4"	6'11-1/8"	12"	5-1/2"
eco-ATC-H 9-2K14-U34	233	187	20	61,500	15,250	10,550	19,330	30	194	5	650	380	10"	17,370	16'3/8"	4'8-1/4"	6'11-1/8"	12"	6-7/8"
eco-ATC-H 9-2L14-U22	244	177	25	66,900	14,570	9,840	18,650	28	186	5	650	380	10"	16,690	16'3/8"	4'8-1/4"	6'11-1/8"	12"	5-1/2"
eco-ATC-H 9-2L14-U34	244	195	25	64,700	15,280	10,550	19,360	30	194	5	650	380	10"	17,400	16'3/8"	4'8-1/4"	6'11-1/8"	12"	6-7/8"
eco-ATC-H 9-3114-U22	235	156	10	52,100	16,890	12,380	21,050	38	263	5	650	380	10"	19,090	16'7-7/8"	4'8-1/4"	7'6-5/8"	19-1/2"	5-1/2"
eco-ATC-H 9-3114-U34	235	164	10	51,000	17,600	13,090	21,760	41	272	5	650	380	10"	19,800	16'7-7/8"	4'8-1/4"	7'6-5/8"	19-1/2"	6-7/8"
eco-ATC-H 9-3114-U22	257	172	15	58,700	17,020	12,380	21,180	38	263	5	650	380	10"	19,220	16'7-7/8"	4'8-1/4"	7'6-5/8"	19-1/2"	5-1/2"
eco-ATC-H 9-3114-U34	257	182	15	57,200	17,730	13,090	21,890	41	272	5	650	380	10"	19,930	16'7-7/8"	4'8-1/4"	7'6-5/8"	19-1/2"	6-7/8"
eco-ATC-H 9-3K14-U22	275	183	20	63,300	17,080	12,380	21,240	38	263	5	650	380	10"	19,280	16'7-7/8"	4'8-1/4"	7'6-5/8"	19-1/2"	5-1/2"
eco-ATC-H 9-3K14-U34	274	193	20	61,600	17,790	13,090	21,950	41	272	5	650	380	10"	19,990	16'7-7/8"	4'8-1/4"	7'6-5/8"	19-1/2"	6-7/8"
eco-ATC-H 9-3L14-U22	288	190	25	66,800	17,110	12,380	21,270	38	263	5	650	380	10"	19,310	16'7-7/8"	4'8-1/4"	7'6-5/8"	19-1/2"	5-1/2"
eco-ATC-H 9-3L14-U34	287	202	25	64,900	17,820	13,090	21,980	41	272	5	650	380	10"	20,020	16'7-7/8"	4'8-1/4"	7'6-5/8"	19-1/2"	6-7/8"
eco-ATC-H 9-3M14-U22	300	197	30	69,800	17,160	12,380	21,320	38	263	5	650	380	10"	19,360	16'7-7/8"	4'8-1/4"	7'6-5/8"	19-1/2"	5-1/2"
eco-ATC-H 9-3M14-U34	299	210	30	67,700	17,870	13,090	22,030	41	272	5	650	380	10"	20,070	16'7-7/8"	4'8-1/4"	7'6-5/8"	19-1/2"	6-7/8"
eco-ATC-H 9-4114-U22	286	177	15	58,000	19,540	14,900	23,780	49	340	5	650	380	10"	21,820	17'3-3/8"	4'8-1/4"	8'2-1/8"	27"	5-1/2"
eco-ATC-H 9-4114-U34	285	183	15	56,700	20,250	15,610	24,490	51	349	5	650	380	10"	22,530	17'3-3/8"	4'8-1/4"	8'2-1/8"	27"	6-7/8"
eco-ATC-H 9-4K14-U22	305	189	20	62,600	19,600	14,900	23,840	49	340	5	650	380	10"	21,880	17'3-3/8"	4'8-1/4"	8'2-1/8"	27"	5-1/2"
eco-ATC-H 9-4K14-U34	304	196	20	61,100	20,310	15,610	24,550	51	349	5	650	380	10"	22,590	17'3-3/8"	4'8-1/4"	8'2-1/8"	27"	6-7/8"
eco-ATC-H 9-4L14-U22	321	198	25	66,100	19,630	14,900	23,870	49	340	5	650	380	10"	21,910	17'3-3/8"	4'8-1/4"	8'2-1/8"	27"	5-1/2"
eco-ATC-H 9-4L14-U34	319	205	25	64,400	20,340	15,610	24,580	51	349	5	650	380	10"	22,620	17'3-3/8"	4'8-1/4"	8'2-1/8"	27"	6-7/8"
eco-ATC-H 9-4M14-U22	334	205	30	69,100	19,680	14,900	23,920	49	340	5	650	380	10"	21,960	17'3-3/8"	4'8-1/4"	8'2-1/8"	27"	5-1/2"
eco-ATC-H 9-4M14-U34	332	213	30	67,300	20,390	15,610	24,630	51	349	5	650	380	10"	22,670	17'3-3/8"	4'8-1/4"	8'2-1/8"	27"	6-7/8"

* Tons at standard conditions: 96.3°F condensing, 20°F suction and 78°F W.B.

** Gallons shown is water in suspension in unit and piping. Allow for additional water in bottom of remote sump to cover pump suction and strainer during operation. (12" would normally be sufficient.)

† Heaviest section is the coil section.

Dimensions are subject to change. Do not use for pre-fabrication. Quantity of coil connections subject to change based on refrigerant and design conditions.

NOTE: Interconnecting piping between ARID *fin Pak*™ Dry Coil outlets and Ellipti-*fin*® Coil inlets are field installed and tested (by others).

Engineering Dimensions & Data

eco-ATC-H 9-2H18-U22 to eco-ATC-H 9-4K18-U34

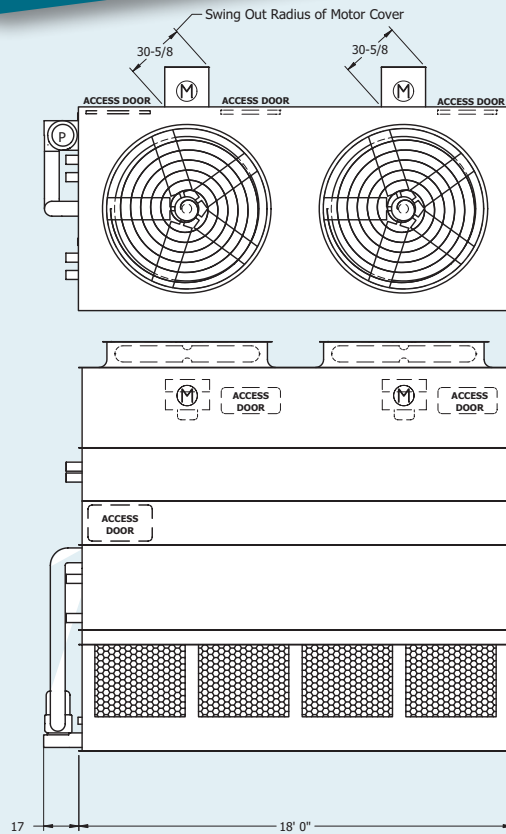
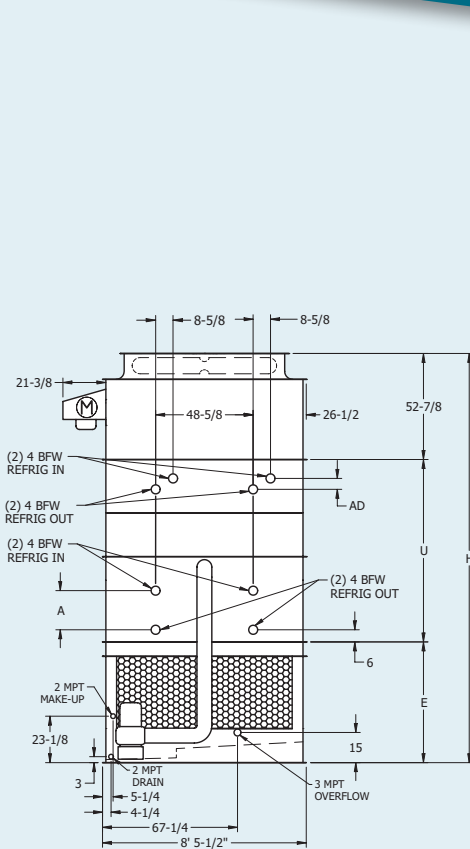

Table 4 Engineering Data

Model No.	R-717 Tons*		Fans		Weights†			Coil Volume (ft ³)	NH ₃ Op. Charge (lbs.)	Spray Pump		Remote Sump		Dimensions (ft)			Dimensions (in)		
	Wet Capacity	Dry Capacity @ 50°F DB Switch Point	HP	CFM	Shipping	Heaviest Section†	Operating			HP	GPM	Gallons Req'd**	Conn. Size	Operating Weight (lbs)	Height H	Lower E	Middle U	Wet Coil A	Dry Coil AD
eco-ATC-H 9-2H18-U22	267	198	2 7.5	71,000	18,860	12,110	24,210	35	236	5	800	510	12"	21,660	16' 4-3/8"	5'1/4"	6' 11-1/8"	12"	5-1/2"
eco-ATC-H 9-2H18-U34	268	216	2 7.5	69,100	19,780	13,020	25,130	38	247	5	800	510	12"	22,580	16' 4-3/8"	5'1/4"	6' 11-1/8"	12"	6-7/8"
eco-ATC-H 9-2I18-U22	285	211	2 10	77,200	18,890	12,110	24,240	35	236	5	800	510	12"	21,690	16' 4-3/8"	5'1/4"	6' 11-1/8"	12"	5-1/2"
eco-ATC-H 9-2I18-U34	286	231	2 10	74,900	19,810	13,020	25,160	38	247	5	800	510	12"	22,610	16' 4-3/8"	5'1/4"	6' 11-1/8"	12"	6-7/8"
eco-ATC-H 9-2J18-U22	311	227	2 15	85,300	19,140	12,110	24,490	35	236	5	800	510	12"	21,940	16' 4-3/8"	5'1/4"	6' 11-1/8"	12"	5-1/2"
eco-ATC-H 9-2J18-U34	311	251	2 15	82,500	20,060	13,020	25,410	38	247	5	800	510	12"	22,860	16' 4-3/8"	5'1/4"	6' 11-1/8"	12"	6-7/8"
eco-ATC-H 9-2K18-U22	331	239	2 20	91,200	19,260	12,110	24,610	35	236	5	800	510	12"	22,060	16' 4-3/8"	5'1/4"	6' 11-1/8"	12"	5-1/2"
eco-ATC-H 9-2K18-U34	331	264	2 20	88,000	20,180	13,020	25,530	38	247	5	800	510	12"	22,980	16' 4-3/8"	5'1/4"	6' 11-1/8"	12"	6-7/8"
eco-ATC-H 9-3H18-U22	314	210	2 7.5	70,500	22,200	15,450	27,650	49	335	5	800	510	12"	25,100	16' 11-7/8"	5'1/4"	7' 6-5/8"	19-1/2"	5-1/2"
eco-ATC-H 9-3H18-U34	314	221	2 7.5	68,900	23,120	16,360	28,570	52	347	5	800	510	12"	26,020	16' 11-7/8"	5'1/4"	7' 6-5/8"	19-1/2"	6-7/8"
eco-ATC-H 9-3I18-U22	335	224	2 10	76,700	22,230	15,450	27,680	49	335	5	800	510	12"	25,130	16' 11-7/8"	5'1/4"	7' 6-5/8"	19-1/2"	5-1/2"
eco-ATC-H 9-3I18-U34	335	237	2 10	74,800	23,150	16,360	28,600	52	347	5	800	510	12"	26,050	16' 11-7/8"	5'1/4"	7' 6-5/8"	19-1/2"	6-7/8"
eco-ATC-H 9-3J18-U22	367	243	2 15	85,000	22,480	15,450	27,930	49	335	5	800	510	12"	25,380	16' 11-7/8"	5'1/4"	7' 6-5/8"	19-1/2"	5-1/2"
eco-ATC-H 9-3J18-U34	366	259	2 15	82,600	23,400	16,360	28,850	52	347	5	800	510	12"	26,300	16' 11-7/8"	5'1/4"	7' 6-5/8"	19-1/2"	6-7/8"
eco-ATC-H 9-3K18-U22	391	257	2 20	91,100	22,600	15,450	28,050	49	335	5	800	510	12"	25,500	16' 11-7/8"	5'1/4"	7' 6-5/8"	19-1/2"	5-1/2"
eco-ATC-H 9-3K18-U34	389	274	2 20	88,400	23,520	16,360	28,970	52	347	5	800	510	12"	26,420	16' 11-7/8"	5'1/4"	7' 6-5/8"	19-1/2"	6-7/8"
eco-ATC-H 9-4H18-U22	348	215	2 7.5	69,400	25,500	18,750	31,050	62	435	5	800	510	12"	28,500	17' 7-3/8"	5'1/4"	8' 2-1/8"	27"	5-1/2"
eco-ATC-H 9-4H18-U34	347	221	2 7.5	68,100	26,420	19,660	31,970	66	447	5	800	510	12"	29,420	17' 7-3/8"	5'1/4"	8' 2-1/8"	27"	6-7/8"
eco-ATC-H 9-4I18-U22	372	232	2 10	75,700	25,530	18,750	31,080	62	435	5	800	510	12"	28,530	17' 7-3/8"	5'1/4"	8' 2-1/8"	27"	5-1/2"
eco-ATC-H 9-4I18-U34	371	239	2 10	74,100	26,450	19,660	32,000	66	447	5	800	510	12"	29,450	17' 7-3/8"	5'1/4"	8' 2-1/8"	27"	6-7/8"
eco-ATC-H 9-4J18-U22	408	252	2 15	84,100	25,780	18,750	31,330	62	435	5	800	510	12"	28,780	17' 7-3/8"	5'1/4"	8' 2-1/8"	27"	5-1/2"
eco-ATC-H 9-4J18-U34	406	262	2 15	82,000	26,700	19,660	32,250	66	447	5	800	510	12"	29,700	17' 7-3/8"	5'1/4"	8' 2-1/8"	27"	6-7/8"
eco-ATC-H 9-4K18-U22	436	267	2 20	90,200	25,900	18,750	31,450	62	435	5	800	510	12"	28,900	17' 7-3/8"	5'1/4"	8' 2-1/8"	27"	5-1/2"
eco-ATC-H 9-4K18-U34	433	279	2 20	87,800	26,820	19,660	32,370	66	447	5	800	510	12"	29,820	17' 7-3/8"	5'1/4"	8' 2-1/8"	27"	6-7/8"

* Tons at standard conditions: 96.3°F condensing, 20°F suction and 78°F W.B.

** Gallons shown is water in suspension in unit and piping. Allow for additional water in bottom of remote sump to cover pump suction and strainer during operation. (12" would normally be sufficient.)

† Heaviest section is the coil section.

Dimensions are subject to change. Do not use for pre-fabrication. Quantity of coil connections subject to change based on refrigerant and design conditions.

NOTE: Interconnecting piping between ARID *fin Pak*™ Dry Coil outlets and Ellipti-*fin*® Coil inlets are field installed and tested (by others).

Engineering Dimensions & Data

eco-ATC-H 9-2H21-U22 to eco-ATC-H 9-4L21-U34

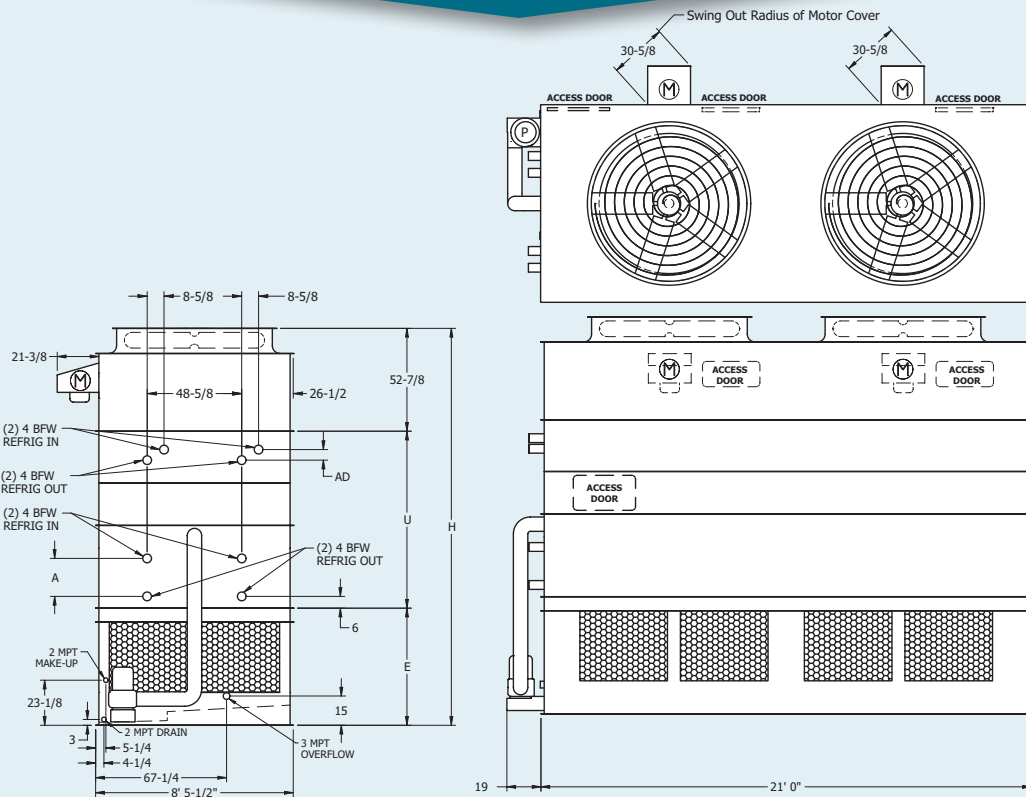

Table 5 Engineering Data

Model No.	R-717 Tons [§]		Fans		Weights [†]			Coil Volume (ft.)	NH ₃ Op. Charge (lbs.)	Spray Pump		Remote Sump			Dimensions (ft)			Dimensions (in)	
	Wet Capacity	Dry Capacity @ 50°F DB Switch Point	HP	CFM	Shipping	Heaviest Section [†]	Operating			HP	GPM	Gallons Req'd ^{**}	Conn. Size	Operating Weight (lbs)	Height H	Lower E	Middle U	Wet Coil A	Dry Coil AD
eco-ATC-H 9-2H21-U22	301	224	2 7.5	79,300	21,620	14,130	27,980	41	274	7.5	1050	590	12"	25,010	16' 4-3/8"	5' 1/4"	6' 11-1/8"	12"	5-1/2"
eco-ATC-H 9-2H21-U34	302	243	2 7.5	77,200	22,690	15,200	29,060	45	287	7.5	1050	590	12"	26,090	16' 4-3/8"	5' 1/4"	6' 11-1/8"	12"	6-7/8"
eco-ATC-H 9-2I21-U22	321	238	2 10	86,100	21,650	14,130	28,010	41	274	7.5	1050	590	12"	25,040	16' 4-3/8"	5' 1/4"	6' 11-1/8"	12"	5-1/2"
eco-ATC-H 9-2I21-U34	322	260	2 10	83,700	22,720	15,200	29,090	45	287	7.5	1050	590	12"	26,120	16' 4-3/8"	5' 1/4"	6' 11-1/8"	12"	6-7/8"
eco-ATC-H 9-2J21-U22	351	258	2 15	95,900	21,900	14,130	28,260	41	274	7.5	1050	590	12"	25,290	16' 4-3/8"	5' 1/4"	6' 11-1/8"	12"	5-1/2"
eco-ATC-H 9-2J21-U34	352	284	2 15	92,900	22,970	15,200	29,340	45	287	7.5	1050	590	12"	26,370	16' 4-3/8"	5' 1/4"	6' 11-1/8"	12"	6-7/8"
eco-ATC-H 9-2K21-U22	373	272	2 20	102,600	22,020	14,130	28,380	41	274	7.5	1050	590	12"	25,410	16' 4-3/8"	5' 1/4"	6' 11-1/8"	12"	5-1/2"
eco-ATC-H 9-2K21-U34	373	300	2 20	99,200	23,090	15,200	29,460	45	287	7.5	1050	590	12"	26,490	16' 4-3/8"	5' 1/4"	6' 11-1/8"	12"	6-7/8"
eco-ATC-H 9-3H21-U22	353	236	2 7.5	78,600	25,290	17,800	31,770	57	390	7.5	1050	590	12"	28,800	16' 11-7/8"	5' 1/4"	7' 6-5/8"	19-1/2"	5-1/2"
eco-ATC-H 9-3H21-U34	354	248	2 7.5	76,900	26,360	18,870	32,850	60	403	7.5	1050	590	12"	29,880	16' 11-7/8"	5' 1/4"	7' 6-5/8"	19-1/2"	6-7/8"
eco-ATC-H 9-3I21-U22	378	253	2 10	85,600	25,320	17,800	31,800	57	390	7.5	1050	590	12"	28,830	16' 11-7/8"	5' 1/4"	7' 6-5/8"	19-1/2"	5-1/2"
eco-ATC-H 9-3I21-U34	377	267	2 10	83,500	26,390	18,870	32,880	60	403	7.5	1050	590	12"	29,910	16' 11-7/8"	5' 1/4"	7' 6-5/8"	19-1/2"	6-7/8"
eco-ATC-H 9-3J21-U22	414	276	2 15	95,600	25,570	17,800	32,050	57	390	7.5	1050	590	12"	29,080	16' 11-7/8"	5' 1/4"	7' 6-5/8"	19-1/2"	5-1/2"
eco-ATC-H 9-3J21-U34	413	293	2 15	93,000	26,640	18,870	33,130	60	403	7.5	1050	590	12"	30,160	16' 11-7/8"	5' 1/4"	7' 6-5/8"	19-1/2"	6-7/8"
eco-ATC-H 9-3K21-U22	441	291	2 20	102,500	25,690	17,800	32,170	57	390	7.5	1050	590	12"	29,200	16' 11-7/8"	5' 1/4"	7' 6-5/8"	19-1/2"	5-1/2"
eco-ATC-H 9-3K21-U34	440	310	2 20	99,500	26,760	18,870	33,250	60	403	7.5	1050	590	12"	30,280	16' 11-7/8"	5' 1/4"	7' 6-5/8"	19-1/2"	6-7/8"
eco-ATC-H 9-3L21-U22	463	303	2 30	108,100	25,790	17,800	32,270	57	390	7.5	1050	590	12"	29,300	16' 11-7/8"	5' 1/4"	7' 6-5/8"	19-1/2"	5-1/2"
eco-ATC-H 9-3L21-U34	461	324	2 30	104,800	26,860	18,870	33,350	60	403	7.5	1050	590	12"	30,380	16' 11-7/8"	5' 1/4"	7' 6-5/8"	19-1/2"	6-7/8"
eco-ATC-H 9-4H21-U22	391	241	2 7.5	77,300	29,140	21,650	35,730	73	507	7.5	1050	590	12"	32,760	17' 7-3/8"	5' 1/4"	8' 2-1/8"	27"	5-1/2"
eco-ATC-H 9-4H21-U34	390	248	2 7.5	75,900	30,210	22,720	36,810	76	520	7.5	1050	590	12"	33,840	17' 7-3/8"	5' 1/4"	8' 2-1/8"	27"	6-7/8"
eco-ATC-H 9-4I21-U22	419	260	2 10	84,300	29,170	21,650	35,760	73	507	7.5	1050	590	12"	32,790	17' 7-3/8"	5' 1/4"	8' 2-1/8"	27"	5-1/2"
eco-ATC-H 9-4I21-U34	417	268	2 10	82,600	30,240	22,720	36,840	76	520	7.5	1050	590	12"	33,870	17' 7-3/8"	5' 1/4"	8' 2-1/8"	27"	6-7/8"
eco-ATC-H 9-4J21-U22	460	285	2 15	94,400	29,420	21,650	36,010	73	507	7.5	1050	590	12"	33,040	17' 7-3/8"	5' 1/4"	8' 2-1/8"	27"	5-1/2"
eco-ATC-H 9-4J21-U34	458	296	2 15	92,200	30,490	22,720	37,090	76	520	7.5	1050	590	12"	34,120	17' 7-3/8"	5' 1/4"	8' 2-1/8"	27"	6-7/8"
eco-ATC-H 9-4K21-U22	491	303	2 20	101,400	29,540	21,650	36,130	3	507	7.5	1050	590	12"	33,160	17' 7-3/8"	5' 1/4"	8' 2-1/8"	27"	5-1/2"
eco-ATC-H 9-4K21-U34	488	315	2 20	98,800	30,610	22,720	37,210	76	520	7.5	1050	590	12"	34,240	17' 7-3/8"	5' 1/4"	8' 2-1/8"	27"	6-7/8"
eco-ATC-H 9-4L21-U22	516	316	2 30	107,000	29,640	21,650	36,230	73	507	7.5	1050	590	12"	33,260	17' 7-3/8"	5' 1/4"	8' 2-1/8"	27"	5-1/2"
eco-ATC-H 9-4L21-U34	512	330	2 30	104,200	30,710	22,720	37,310	76	520	7.5	1050	590	12"	34,340	17' 7-3/8"	5' 1/4"	8' 2-1/8"	27"	6-7/8"

* Tons at standard conditions: 96.3°F condensing, 20°F suction and 78°F W.B.

** Gallons shown is water in suspension in unit and piping. Allow for additional water in bottom of remote sump to cover pump suction and strainer during operation. (12" would normally be sufficient.)

† Heaviest section is the coil section.

Dimensions are subject to change. Do not use for pre-fabrication. Quantity of coil connections subject to change based on refrigerant and design conditions.

NOTE: Interconnecting piping between ARID *fin Pak*™ Dry Coil outlets and Ellipti-*fin*® Coil inlets are field installed and tested (by others).

Engineering Dimensions & Data

eco-ATC-H 17-2114-U22 to eco-ATC-H 17-4M14-U34

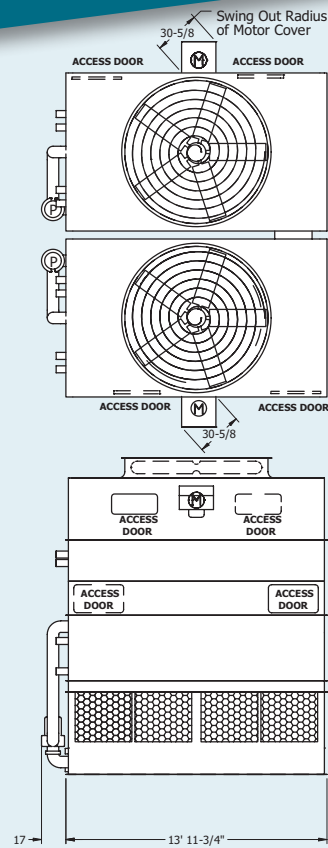
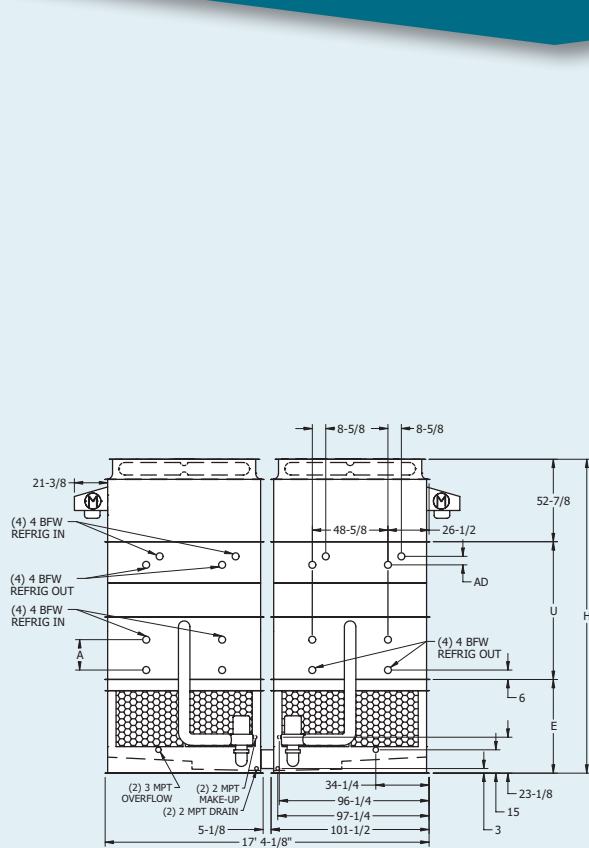

Table 7 Engineering Data

Model No.	R-717 Tons*		Fans		Weights†			Coil Volume (ft ³)	NH ₃ Op. Charge (lbs.)	Spray Pump		Remote Sump		Dimensions (ft)			Dimensions (in)		
	Wet Capacity	Dry Capacity @ 50°F DB Switch Point	HP	CFM	Shipping	Heaviest Section†	Operating			HP	GPM	Gallons Req'd**	Conn. Size	Operating Weight (lbs)	Height H	Lower E	Middle U	Wet Coil A	Dry Coil AD
eco-ATC-H 17-2114-U22	346	266	2 10	105,100	28,480	9,730	36,640	55	371	2 5	1300	760	2 10"	32,720	16'10-3/8"	5'6-1/4"	6'11-1/8"	12"	5-1/2"
eco-ATC-H 17-2114-U34	350	308	2 10	102,300	29,890	10,440	38,070	60	389	2 5	1300	760	2 10"	34,150	16'10-3/8"	5'6-1/4"	6'11-1/8"	12"	6-7/8"
eco-ATC-H 17-2114-U22	378	290	2 15	118,000	28,740	9,730	36,900	55	371	2 5	1300	760	2 10"	32,980	16'10-3/8"	5'6-1/4"	6'11-1/8"	12"	5-1/2"
eco-ATC-H 17-2114-U34	382	337	2 15	114,500	30,150	10,440	38,330	60	389	2 5	1300	760	2 10"	34,410	16'10-3/8"	5'6-1/4"	6'11-1/8"	12"	6-7/8"
eco-ATC-H 17-2K14-U22	403	306	2 20	127,000	28,860	9,730	37,020	55	371	2 5	1300	760	2 10"	33,100	16'10-3/8"	5'6-1/4"	6'11-1/8"	12"	5-1/2"
eco-ATC-H 17-2K14-U34	406	356	2 20	123,000	30,270	10,440	38,450	60	389	2 5	1300	760	2 10"	34,530	16'10-3/8"	5'6-1/4"	6'11-1/8"	12"	6-7/8"
eco-ATC-H 17-2L14-U22	422	317	2 25	133,800	28,920	9,730	37,080	55	371	2 5	1300	760	2 10"	33,160	16'10-3/8"	5'6-1/4"	6'11-1/8"	12"	5-1/2"
eco-ATC-H 17-2L14-U34	426	371	2 25	129,300	30,330	10,440	38,510	60	389	2 5	1300	760	2 10"	34,590	16'10-3/8"	5'6-1/4"	6'11-1/8"	12"	6-7/8"
eco-ATC-H 17-3114-U22	405	281	2 10	104,200	33,780	12,380	42,100	76	526	2 5	1300	760	2 10"	38,180	17'5-7/8"	5'6-1/4"	7'6-5/8"	19-1/2"	5-1/2"
eco-ATC-H 17-3114-U34	408	314	2 10	101,900	35,190	13,090	43,530	81	543	2 5	1300	760	2 10"	39,610	17'5-7/8"	5'6-1/4"	7'6-5/8"	19-1/2"	6-7/8"
eco-ATC-H 17-3114-U22	445	307	2 15	117,500	34,040	12,380	42,360	76	526	2 5	1300	760	2 10"	38,440	17'5-7/8"	5'6-1/4"	7'6-5/8"	19-1/2"	5-1/2"
eco-ATC-H 17-3114-U34	447	346	2 15	114,500	35,450	13,090	43,790	81	543	2 5	1300	760	2 10"	39,870	17'5-7/8"	5'6-1/4"	7'6-5/8"	19-1/2"	6-7/8"
eco-ATC-H 17-3K14-U22	474	324	2 20	126,700	34,160	12,380	42,480	76	526	2 5	1300	760	2 10"	38,560	17'5-7/8"	5'6-1/4"	7'6-5/8"	19-1/2"	5-1/2"
eco-ATC-H 17-3K14-U34	476	367	2 20	123,200	35,570	13,090	43,910	81	543	2 5	1300	760	2 10"	39,990	17'5-7/8"	5'6-1/4"	7'6-5/8"	19-1/2"	6-7/8"
eco-ATC-H 17-3L14-U22	498	337	2 25	133,700	34,220	12,380	42,540	76	526	2 5	1300	760	2 10"	38,620	17'5-7/8"	5'6-1/4"	7'6-5/8"	19-1/2"	5-1/2"
eco-ATC-H 17-3L14-U34	500	383	2 25	129,700	35,630	13,090	43,970	81	543	2 5	1300	760	2 10"	40,050	17'5-7/8"	5'6-1/4"	7'6-5/8"	19-1/2"	6-7/8"
eco-ATC-H 17-3M14-U22	518	348	2 30	139,600	34,320	12,380	42,640	76	526	2 5	1300	760	2 10"	38,720	17'5-7/8"	5'6-1/4"	7'6-5/8"	19-1/2"	5-1/2"
eco-ATC-H 17-3M14-U34	520	396	2 30	135,300	35,730	13,090	44,070	81	543	2 5	1300	760	2 10"	40,150	17'5-7/8"	5'6-1/4"	7'6-5/8"	19-1/2"	6-7/8"
eco-ATC-H 17-4114-U22	493	319	2 15	115,900	39,080	14,900	47,560	97	680	2 5	1300	760	2 10"	43,640	18'1-3/8"	5'6-1/4"	8'2-1/8"	27"	5-1/2"
eco-ATC-H 17-4114-U34	495	350	2 15	113,400	40,490	15,610	48,990	102	698	2 5	1300	760	2 10"	45,070	18'1-3/8"	5'6-1/4"	8'2-1/8"	27"	6-7/8"
eco-ATC-H 17-4K14-U22	527	338	2 20	125,200	39,200	14,900	47,680	97	680	2 5	1300	760	2 10"	43,760	18'1-3/8"	5'6-1/4"	8'2-1/8"	27"	5-1/2"
eco-ATC-H 17-4K14-U34	528	373	2 20	122,200	40,610	15,610	49,110	102	698	2 5	1300	760	2 10"	45,190	18'1-3/8"	5'6-1/4"	8'2-1/8"	27"	6-7/8"
eco-ATC-H 17-4L14-U22	554	352	2 25	132,300	39,260	14,900	47,740	97	680	2 5	1300	760	2 10"	43,820	18'1-3/8"	5'6-1/4"	8'2-1/8"	27"	5-1/2"
eco-ATC-H 17-4L14-U34	554	390	2 25	128,900	40,670	15,610	49,170	102	698	2 5	1300	760	2 10"	45,250	18'1-3/8"	5'6-1/4"	8'2-1/8"	27"	6-7/8"
eco-ATC-H 17-4M14-U22	577	363	2 30	138,300	39,360	14,900	47,840	97	680	2 5	1300	760	2 10"	43,920	18'1-3/8"	5'6-1/4"	8'2-1/8"	27"	5-1/2"
eco-ATC-H 17-4M14-U34	577	404	2 30	134,500	40,770	15,610	49,270	102	698	2 5	1300	760	2 10"	45,350	18'1-3/8"	5'6-1/4"	8'2-1/8"	27"	6-7/8"

* Tons at standard conditions: 96.3°F condensing, 20°F suction and 78°F W.B.

** Gallons shown is water in suspension in unit and piping. Allow for additional water in bottom of remote sump to cover pump suction and strainer during operation. (12" would normally be sufficient.)

† Heaviest section is the coil section.

Dimensions are subject to change. Do not use for pre-fabrication. Quantity of coil connections subject to change based on refrigerant and design conditions.

NOTE: Interconnecting piping between ARID *fin Pak*™ Dry Coil outlets and Ellipti-*fin*® Coil inlets are field installed and tested (by others).

Engineering Dimensions & Data

eco-ATC-H 10-2I12-U22 to eco-ATC-H 10-4M12-U34

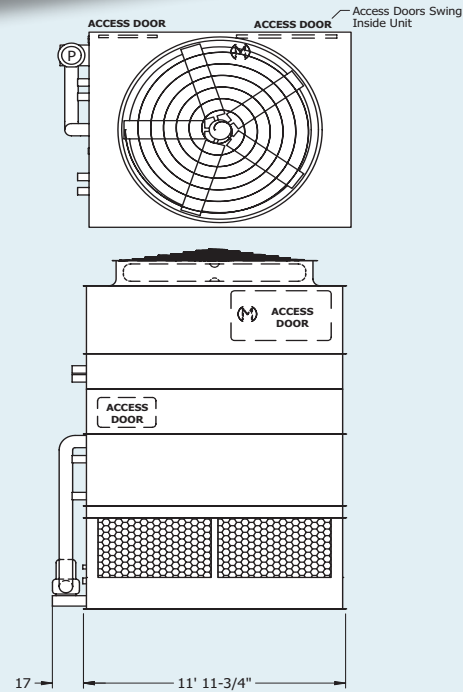
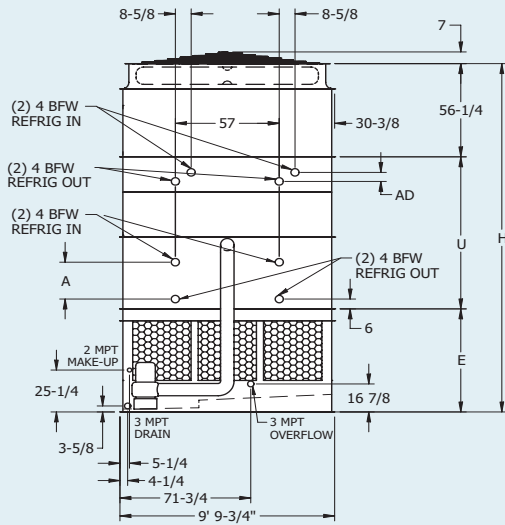

Table 8 Engineering Data

Model No.	R-717 Tons [*]		Fans		Weights [†]			Coil Volume (ft. ³)	NH ₃ Op. Charge (lbs.)	Spray Pump		Remote Sump		Dimensions (ft)			Dimensions (in)		
	Wet Capacity	Dry Capacity @ 50°F DB Switch Point	HP	CFM	Shipping	Heaviest Section [†]	Operating			HP	GPM	Gallons Req'd ^{**}	Conn. Size	Operating Weight (lbs)	Height H	Lower E	Middle U	Wet Coil A	Dry Coil AD
eco-ATC-H 10-2I12-U22	199	148	10	52,500	15,850	10,870	20,860	28	188	5	685	420	12"	17,290	16' 9-7/8"	5' 2-1/4"	6' 11-3/8"	13-3/4"	5-1/2"
eco-ATC-H 10-2I12-U34	200	161	10	51,100	16,570	11,580	21,580	31	198	5	685	420	12"	18,010	16' 9-7/8"	5' 2-1/4"	6' 11-3/8"	13-3/4"	6-7/8"
eco-ATC-H 10-2I12-U22	218	162	15	59,000	15,980	10,870	20,990	28	188	5	685	420	12"	17,420	16' 9-7/8"	5' 2-1/4"	6' 11-3/8"	13-3/4"	5-1/2"
eco-ATC-H 10-2I12-U34	219	177	15	57,300	16,700	11,580	21,710	31	198	5	685	420	12"	18,140	16' 9-7/8"	5' 2-1/4"	6' 11-3/8"	13-3/4"	6-7/8"
eco-ATC-H 10-2K12-U22	232	171	20	63,500	16,040	10,870	21,050	28	188	5	685	420	12"	17,480	16' 9-7/8"	5' 2-1/4"	6' 11-3/8"	13-3/4"	5-1/2"
eco-ATC-H 10-2K12-U34	233	188	20	61,500	16,760	11,580	21,770	31	198	5	685	420	12"	18,200	16' 9-7/8"	5' 2-1/4"	6' 11-3/8"	13-3/4"	6-7/8"
eco-ATC-H 10-2L12-U22	244	178	25	66,900	16,070	10,870	21,080	28	188	5	685	420	12"	17,510	16' 9-7/8"	5' 2-1/4"	6' 11-3/8"	13-3/4"	5-1/2"
eco-ATC-H 10-2L12-U34	244	196	25	64,700	16,790	11,580	21,800	31	198	5	685	420	12"	18,230	16' 9-7/8"	5' 2-1/4"	6' 11-3/8"	13-3/4"	6-7/8"
eco-ATC-H 10-2M12-U22	254	183	30	69,800	16,120	10,870	21,130	28	188	5	685	420	12"	17,560	16' 9-7/8"	5' 2-1/4"	6' 11-3/8"	13-3/4"	5-1/2"
eco-ATC-H 10-2M12-U34	253	202	30	67,400	16,840	11,580	21,850	31	198	5	685	420	12"	18,280	16' 9-7/8"	5' 2-1/4"	6' 11-3/8"	13-3/4"	6-7/8"
eco-ATC-H 10-3I12-U22	234	156	10	52,100	18,310	13,330	23,390	39	266	5	685	420	12"	19,820	17' 6-3/8"	5' 2-1/4"	7' 7-7/8"	22-1/4"	5-1/2"
eco-ATC-H 10-3I12-U34	234	164	10	50,900	19,030	14,040	24,110	41	275	5	685	420	12"	20,540	17' 6-3/8"	5' 2-1/4"	7' 7-7/8"	22-1/4"	6-7/8"
eco-ATC-H 10-3I12-U22	257	172	15	58,700	18,440	13,330	23,520	39	266	5	685	420	12"	19,950	17' 6-3/8"	5' 2-1/4"	7' 7-7/8"	22-1/4"	5-1/2"
eco-ATC-H 10-3I12-U34	257	182	15	57,200	19,160	14,040	24,240	41	275	5	685	420	12"	20,670	17' 6-3/8"	5' 2-1/4"	7' 7-7/8"	22-1/4"	6-7/8"
eco-ATC-H 10-3K12-U22	274	183	20	63,300	18,500	13,330	23,580	39	266	5	685	420	12"	20,010	17' 6-3/8"	5' 2-1/4"	7' 7-7/8"	22-1/4"	5-1/2"
eco-ATC-H 10-3K12-U34	274	194	20	61,600	19,220	14,040	24,300	41	275	5	685	420	12"	20,730	17' 6-3/8"	5' 2-1/4"	7' 7-7/8"	22-1/4"	6-7/8"
eco-ATC-H 10-3L12-U22	288	191	25	66,800	18,530	13,330	23,610	39	266	5	685	420	12"	20,040	17' 6-3/8"	5' 2-1/4"	7' 7-7/8"	22-1/4"	5-1/2"
eco-ATC-H 10-3L12-U34	287	203	25	64,900	19,250	14,040	24,330	41	275	5	685	420	12"	20,760	17' 6-3/8"	5' 2-1/4"	7' 7-7/8"	22-1/4"	6-7/8"
eco-ATC-H 10-3M12-U22	300	197	30	69,800	18,580	13,330	23,660	39	266	5	685	420	12"	20,090	17' 6-3/8"	5' 2-1/4"	7' 7-7/8"	22-1/4"	5-1/2"
eco-ATC-H 10-3M12-U34	298	210	30	67,700	19,300	14,040	24,380	41	275	5	685	420	12"	20,810	17' 6-3/8"	5' 2-1/4"	7' 7-7/8"	22-1/4"	6-7/8"
eco-ATC-H 10-4I12-U22	260	160	10	51,300	20,910	15,930	26,070	49	343	5	685	420	12"	22,500	18' 2-7/8"	5' 2-1/4"	8' 4-3/8"	30-3/4"	5-1/2"
eco-ATC-H 10-4I12-U34	259	164	10	50,300	21,630	16,640	26,790	52	353	5	685	420	12"	23,220	18' 2-7/8"	5' 2-1/4"	8' 4-3/8"	30-3/4"	6-7/8"
eco-ATC-H 10-4I12-U22	286	178	15	57,900	21,040	15,930	26,200	49	343	5	685	420	12"	22,630	18' 2-7/8"	5' 2-1/4"	8' 4-3/8"	30-3/4"	5-1/2"
eco-ATC-H 10-4I12-U34	284	183	15	56,700	21,760	16,640	26,920	52	353	5	685	420	12"	23,350	18' 2-7/8"	5' 2-1/4"	8' 4-3/8"	30-3/4"	6-7/8"
eco-ATC-H 10-4K12-U22	305	189	20	62,600	21,100	15,930	26,260	49	343	5	685	420	12"	22,690	18' 2-7/8"	5' 2-1/4"	8' 4-3/8"	30-3/4"	5-1/2"
eco-ATC-H 10-4K12-U34	303	196	20	61,100	21,820	16,640	26,980	52	353	5	685	420	12"	23,410	18' 2-7/8"	5' 2-1/4"	8' 4-3/8"	30-3/4"	6-7/8"
eco-ATC-H 10-4L12-U22	321	198	25	66,100	21,130	15,930	26,290	49	343	5	685	420	12"	22,720	18' 2-7/8"	5' 2-1/4"	8' 4-3/8"	30-3/4"	5-1/2"
eco-ATC-H 10-4L12-U34	319	205	25	64,400	21,850	16,640	27,010	52	353	5	685	420	12"	23,440	18' 2-7/8"	5' 2-1/4"	8' 4-3/8"	30-3/4"	6-7/8"
eco-ATC-H 10-4M12-U22	334	205	30	69,100	21,180	15,930	26,340	49	343	5	685	420	12"	22,770	18' 2-7/8"	5' 2-1/4"	8' 4-3/8"	30-3/4"	5-1/2"
eco-ATC-H 10-4M12-U34	332	213	30	67,300	21,900	16,640	27,060	52	353	5	685	420	12"	23,490	18' 2-7/8"	5' 2-1/4"	8' 4-3/8"	30-3/4"	6-7/8"

* Tons at standard conditions: 96.3°F condensing, 20°F suction and 78°F W.B.

** Gallons shown is water in suspension in unit and piping. Allow for additional water in bottom of remote sump to cover pump suction and strainer during operation. (12" would normally be sufficient.)

† Heaviest section is the coil section.

Dimensions are subject to change. Do not use for pre-fabrication. Quantity of coil connections subject to change based on refrigerant and design conditions.

NOTE: Interconnecting piping between ARID *fin Pak*™ Dry Coil outlets and Ellipti-*fin*® Coil inlets are field installed and tested (by others).

Engineering Dimensions & Data

eco-ATC-H 10-2I18-U22 to eco-ATC-H 10-4N18-U34

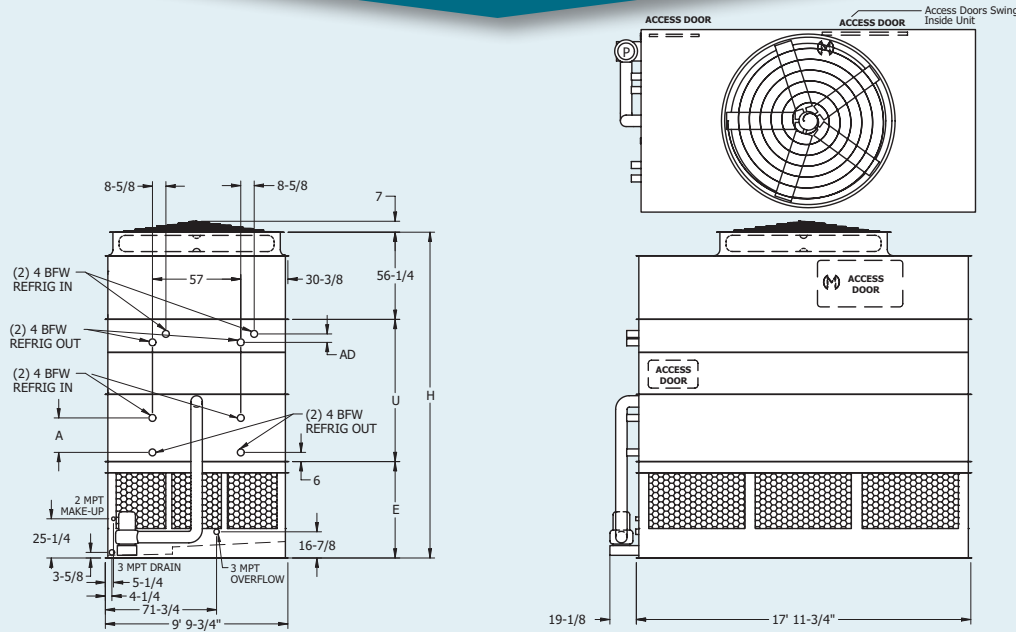

Table 9 Engineering Data

Model No.	R-717 Tons*		Fans		Weights†			Coil Volume (ft ³)	NH ₃ Op. Charge (lbs.)	Spray Pump		Remote Sump		Dimensions (ft)			Dimensions (in)		
	Wet Capacity	Dry Capacity @ 50°F DB Switch Point	HP	CFM	Shipping	Heaviest Section†	Operating			HP	GPM	Gallons Req'd**	Conn. Size	Operating Weight (lbs)	Height H	Lower E	Middle U	Wet Coil A	Dry Coil AD
eco-ATC-H 10-2I18-U22	275	204	10	70,400	22,350	15,590	29,930	41	277	7.5	1030	630	12"	24,680	16' 9-7/8"	5' 2-1/4"	6' 11-3/8"	13-3/4"	5-1/2"
eco-ATC-H 10-2I18-U34	276	221	10	68,900	23,430	16,670	31,020	45	290	7.5	1030	630	12"	25,770	16' 9-7/8"	5' 2-1/4"	6' 11-3/8"	13-3/4"	6-7/8"
eco-ATC-H 10-2I18-U22	301	224	15	79,400	22,480	15,590	30,060	41	277	7.5	1030	630	12"	24,810	16' 9-7/8"	5' 2-1/4"	6' 11-3/8"	13-3/4"	5-1/2"
eco-ATC-H 10-2I18-U34	303	244	15	77,400	23,560	16,670	31,150	45	290	7.5	1030	630	12"	25,900	16' 9-7/8"	5' 2-1/4"	6' 11-3/8"	13-3/4"	6-7/8"
eco-ATC-H 10-2K18-U22	321	239	20	86,300	22,540	15,590	30,120	41	277	7.5	1030	630	12"	24,870	16' 9-7/8"	5' 2-1/4"	6' 11-3/8"	13-3/4"	5-1/2"
eco-ATC-H 10-2K18-U34	323	261	20	83,900	23,620	16,670	31,210	45	290	7.5	1030	630	12"	25,960	16' 9-7/8"	5' 2-1/4"	6' 11-3/8"	13-3/4"	6-7/8"
eco-ATC-H 10-2L18-U22	338	251	25	92,000	22,570	15,590	30,150	41	277	7.5	1030	630	12"	24,900	16' 9-7/8"	5' 2-1/4"	6' 11-3/8"	13-3/4"	5-1/2"
eco-ATC-H 10-2L18-U34	339	275	25	89,200	23,650	16,670	31,240	45	290	7.5	1030	630	12"	25,990	16' 9-7/8"	5' 2-1/4"	6' 11-3/8"	13-3/4"	6-7/8"
eco-ATC-H 10-2M18-U22	352	259	30	96,100	22,620	15,590	30,200	41	277	7.5	1030	630	12"	24,950	16' 9-7/8"	5' 2-1/4"	6' 11-3/8"	13-3/4"	5-1/2"
eco-ATC-H 10-2M18-U34	352	285	30	93,100	23,700	16,670	31,290	45	290	7.5	1030	630	12"	26,040	16' 9-7/8"	5' 2-1/4"	6' 11-3/8"	13-3/4"	6-7/8"
eco-ATC-H 10-2N18-U22	374	273	40	102,800	22,780	15,590	30,360	41	277	7.5	1030	630	12"	25,110	16' 9-7/8"	5' 2-1/4"	6' 11-3/8"	13-3/4"	5-1/2"
eco-ATC-H 10-2N18-U34	374	301	40	99,500	23,860	16,670	31,450	45	290	7.5	1030	630	12"	26,200	16' 9-7/8"	5' 2-1/4"	6' 11-3/8"	13-3/4"	6-7/8"
eco-ATC-H 10-3I18-U22	321	214	10	69,600	26,070	19,310	33,770	57	394	7.5	1030	630	12"	28,520	17' 6-3/8"	5' 2-1/4"	7' 7-7/8"	22-1/4"	5-1/2"
eco-ATC-H 10-3I18-U34	322	223	10	68,300	27,150	20,390	34,860	61	407	7.5	1030	630	12"	29,610	17' 6-3/8"	5' 2-1/4"	7' 7-7/8"	22-1/4"	6-7/8"
eco-ATC-H 10-3I18-U22	354	236	15	78,600	26,200	19,310	33,900	57	394	7.5	1030	630	12"	28,650	17' 6-3/8"	5' 2-1/4"	7' 7-7/8"	22-1/4"	5-1/2"
eco-ATC-H 10-3I18-U34	354	248	15	77,000	27,280	20,390	34,990	61	407	7.5	1030	630	12"	29,740	17' 6-3/8"	5' 2-1/4"	7' 7-7/8"	22-1/4"	6-7/8"
eco-ATC-H 10-3K18-U22	378	254	20	85,700	26,260	19,310	33,960	57	394	7.5	1030	630	12"	28,710	17' 6-3/8"	5' 2-1/4"	7' 7-7/8"	22-1/4"	5-1/2"
eco-ATC-H 10-3K18-U34	378	267	20	83,700	27,340	20,390	35,050	61	407	7.5	1030	630	12"	29,800	17' 6-3/8"	5' 2-1/4"	7' 7-7/8"	22-1/4"	6-7/8"
eco-ATC-H 10-3L18-U22	398	267	25	91,500	26,290	19,310	33,990	57	394	7.5	1030	630	12"	28,740	17' 6-3/8"	5' 2-1/4"	7' 7-7/8"	22-1/4"	5-1/2"
eco-ATC-H 10-3L18-U34	397	283	25	89,200	27,370	20,390	35,080	61	407	7.5	1030	630	12"	29,830	17' 6-3/8"	5' 2-1/4"	7' 7-7/8"	22-1/4"	6-7/8"
eco-ATC-H 10-3M18-U22	414	277	30	95,700	26,340	19,310	34,040	57	394	7.5	1030	630	12"	28,790	17' 6-3/8"	5' 2-1/4"	7' 7-7/8"	22-1/4"	5-1/2"
eco-ATC-H 10-3M18-U34	414	294	30	93,200	27,420	20,390	35,130	61	407	7.5	1030	630	12"	29,880	17' 6-3/8"	5' 2-1/4"	7' 7-7/8"	22-1/4"	6-7/8"
eco-ATC-H 10-3N18-U22	442	292	40	102,600	26,500	19,310	34,200	57	394	7.5	1030	630	12"	28,950	17' 6-3/8"	5' 2-1/4"	7' 7-7/8"	22-1/4"	5-1/2"
eco-ATC-H 10-3N18-U34	440	311	40	99,700	27,580	20,390	35,290	61	407	7.5	1030	630	12"	30,040	17' 6-3/8"	5' 2-1/4"	7' 7-7/8"	22-1/4"	6-7/8"
eco-ATC-H 10-4I18-U22	355	217	10	68,300	29,940	23,180	37,760	73	511	7.5	1030	630	12"	32,510	18' 2-7/8"	5' 2-1/4"	8' 4-3/8"	30-3/4"	5-1/2"
eco-ATC-H 10-4I18-U34	355	222	10	67,300	31,020	24,260	38,850	77	524	7.5	1030	630	12"	33,600	18' 2-7/8"	5' 2-1/4"	8' 4-3/8"	30-3/4"	6-7/8"
eco-ATC-H 10-4I18-U22	392	242	15	77,300	30,070	23,180	37,890	73	511	7.5	1030	630	12"	32,640	18' 2-7/8"	5' 2-1/4"	8' 4-3/8"	30-3/4"	5-1/2"
eco-ATC-H 10-4I18-U34	391	248	15	76,000	31,150	24,260	38,980	77	524	7.5	1030	630	12"	33,730	18' 2-7/8"	5' 2-1/4"	8' 4-3/8"	30-3/4"	6-7/8"
eco-ATC-H 10-4K18-U22	419	261	20	84,400	30,130	23,180	37,950	73	511	7.5	1030	630	12"	32,700	18' 2-7/8"	5' 2-1/4"	8' 4-3/8"	30-3/4"	5-1/2"
eco-ATC-H 10-4K18-U34	418	269	20	82,700	31,210	24,260	39,040	77	524	7.5	1030	630	12"	33,790	18' 2-7/8"	5' 2-1/4"	8' 4-3/8"	30-3/4"	6-7/8"
eco-ATC-H 10-4L18-U22	442	275	25	90,200	30,160	23,180	37,980	73	511	7.5	1030	630	12"	32,730	18' 2-7/8"	5' 2-1/4"	8' 4-3/8"	30-3/4"	5-1/2"
eco-ATC-H 10-4L18-U34	440	285	25	88,300	31,240	24,260	39,070	77	524	7.5	1030	630	12"	33,820	18' 2-7/8"	5' 2-1/4"	8' 4-3/8"	30-3/4"	6-7/8"
eco-ATC-H 10-4M18-U22	460	286	30	94,500	30,210	23,180	38,030	73	511	7.5	1030	630	12"	32,780	18' 2-7/8"	5' 2-1/4"	8' 4-3/8"	30-3/4"	5-1/2"
eco-ATC-H 10-4M18-U34	458	297	30	92,400	31,290	24,260	39,120	77	524	7.5	1030	630	12"	33,870	18' 2-7/8"	5' 2-1/4"	8' 4-3/8"	30-3/4"	6-7/8"
eco-ATC-H 10-4N18-U22	492	303	40	101,500	30,370	23,180	38,190	73	511	7.5	1030	630	12"	32,940	18' 2-7/8"	5' 2-1/4"	8' 4-3/8"	30-3/4"	5-1/2"
eco-ATC-H 10-4N18-U34	489	316	40	99,000	31,450	24,260	39,280	77	524	7.5	1030	630	12"	34,030	18' 2-7/8"	5' 2-1/4"	8' 4-3/8"	30-3/4"	6-7/8"

* Tons at standard conditions: 96.3°F condensing, 20°F suction and 78°F W.B.

** Gallons shown is water in suspension in unit and piping. Allow for additional water in bottom of remote sump to cover pump suction and strainer during operation. (12" would normally be sufficient.)

† Heaviest section is the coil section.

‡ Dimensions are subject to change. Do not use for pre-fabrication. Quantity of coil connections subject to change based on refrigerant and design conditions.

NOTE: Interconnecting piping between ARID fin Pak™ Dry Coil outlets and Ellipti-fin® Coil inlets are field installed and tested (by others).

Engineering Dimensions & Data

eco-ATC-H 10-2I24-U22 to eco-ATC-H 10-4M24-U34

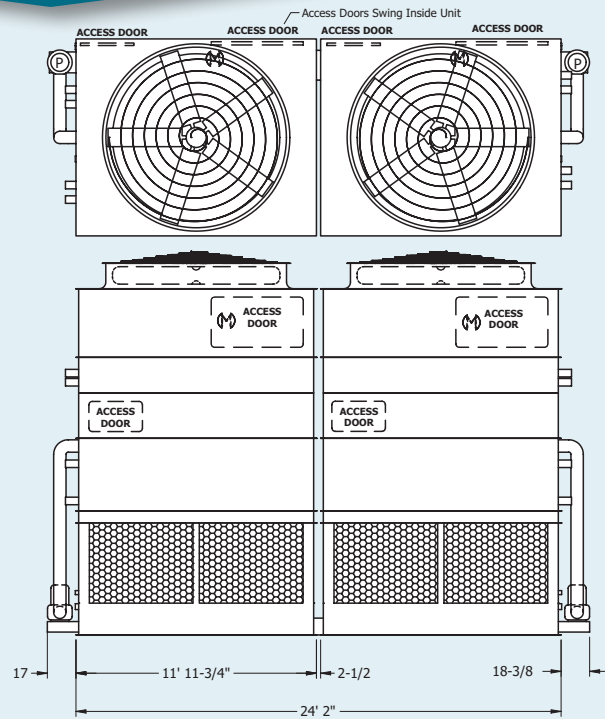
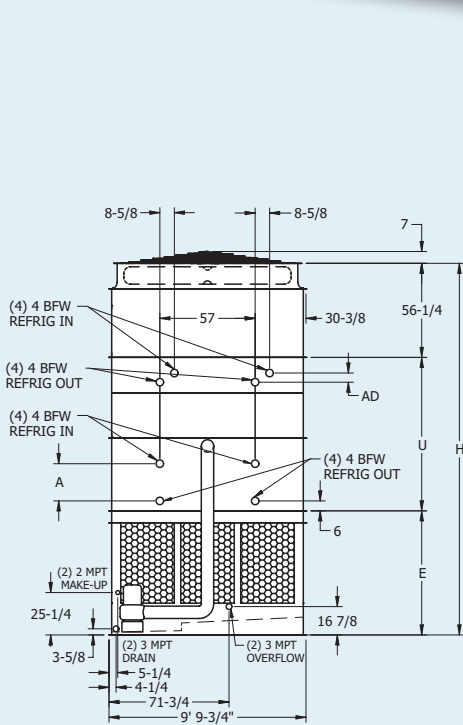

Table 10 Engineering Data

Model No.	R-717 Tons*		Fans		Weights†			Coil Volume (ft.)	NH3 Op. Charge (lbs.)	Spray Pump		Remote Sump		Dimensions (ft)			Dimensions (in)		
	Wet Capacity	Dry Capacity @ 50°F DB Switch Point	HP	CFM	Shipping	Heaviest Section†	Operating			HP	GPM	Gallons Req'd**	Conn. Size	Operating Weight (lbs)	Height H	Lower E	Middle U	Wet Coil A	Dry Coil AD
eco-ATC-H 10-2I24-U22	345	266	2 10	105,100	31,630	10,830	41,640	56	376	2 5	1370	840	2 12"	34,500	17' 9-7/8"	6' 2-1/4"	6' 11-3/8"	13-3/4"	5-1/2"
eco-ATC-H 10-2I24-U34	350	308	2 10	102,300	33,050	11,540	43,090	61	396	2 5	1370	840	2 12"	35,950	17' 9-7/8"	6' 2-1/4"	6' 11-3/8"	13-3/4"	6-7/8"
eco-ATC-H 10-2J24-U22	378	290	2 15	118,000	31,890	10,830	41,900	56	376	2 5	1370	840	2 12"	34,760	17' 9-7/8"	6' 2-1/4"	6' 11-3/8"	13-3/4"	5-1/2"
eco-ATC-H 10-2J24-U34	382	337	2 15	114,500	33,310	11,540	43,350	61	396	2 5	1370	840	2 12"	36,210	17' 9-7/8"	6' 2-1/4"	6' 11-3/8"	13-3/4"	6-7/8"
eco-ATC-H 10-2K24-U22	403	306	2 20	127,000	32,010	10,830	42,020	56	376	2 5	1370	840	2 12"	34,880	17' 9-7/8"	6' 2-1/4"	6' 11-3/8"	13-3/4"	5-1/2"
eco-ATC-H 10-2K24-U34	406	357	2 20	123,000	33,430	11,540	43,470	61	396	2 5	1370	840	2 12"	36,330	17' 9-7/8"	6' 2-1/4"	6' 11-3/8"	13-3/4"	6-7/8"
eco-ATC-H 10-2L24-U22	422	318	2 25	133,800	32,070	10,830	42,080	56	376	2 5	1370	840	2 12"	34,940	17' 9-7/8"	6' 2-1/4"	6' 11-3/8"	13-3/4"	5-1/2"
eco-ATC-H 10-2L24-U34	426	372	2 25	129,400	33,490	11,540	43,530	61	396	2 5	1370	840	2 12"	36,390	17' 9-7/8"	6' 2-1/4"	6' 11-3/8"	13-3/4"	6-7/8"
eco-ATC-H 10-2M24-U22	439	328	2 30	139,600	32,170	10,830	42,180	56	376	2 5	1370	840	2 12"	35,040	17' 9-7/8"	6' 2-1/4"	6' 11-3/8"	13-3/4"	5-1/2"
eco-ATC-H 10-2M24-U34	442	384	2 30	134,800	33,590	11,540	43,630	61	396	2 5	1370	840	2 12"	36,490	17' 9-7/8"	6' 2-1/4"	6' 11-3/8"	13-3/4"	6-7/8"
eco-ATC-H 10-3I24-U22	405	281	2 10	104,200	36,630	13,330	46,780	77	531	2 5	1370	840	2 12"	39,640	18' 6-3/8"	6' 2-1/4"	7' 7-7/8"	22-1/4"	5-1/2"
eco-ATC-H 10-3I24-U34	408	315	2 10	101,900	38,050	14,040	48,230	82	551	2 5	1370	840	2 12"	41,090	18' 6-3/8"	6' 2-1/4"	7' 7-7/8"	22-1/4"	6-7/8"
eco-ATC-H 10-3J24-U22	444	307	2 15	117,400	36,890	13,330	47,040	77	531	2 5	1370	840	2 12"	39,900	18' 6-3/8"	6' 2-1/4"	7' 7-7/8"	22-1/4"	5-1/2"
eco-ATC-H 10-3J24-U34	447	346	2 15	114,400	38,310	14,040	48,490	82	551	2 5	1370	840	2 12"	41,350	18' 6-3/8"	6' 2-1/4"	7' 7-7/8"	22-1/4"	6-7/8"
eco-ATC-H 10-3K24-U22	474	325	2 20	126,600	37,010	13,330	47,160	77	531	2 5	1370	840	2 12"	40,020	18' 6-3/8"	6' 2-1/4"	7' 7-7/8"	22-1/4"	5-1/2"
eco-ATC-H 10-3K24-U34	476	368	2 20	123,100	38,430	14,040	48,610	82	551	2 5	1370	840	2 12"	41,470	18' 6-3/8"	6' 2-1/4"	7' 7-7/8"	22-1/4"	6-7/8"
eco-ATC-H 10-3L24-U22	498	338	2 25	133,600	37,070	13,330	47,220	77	531	2 5	1370	840	2 12"	40,080	18' 6-3/8"	6' 2-1/4"	7' 7-7/8"	22-1/4"	5-1/2"
eco-ATC-H 10-3L24-U34	500	383	2 25	129,700	38,490	14,040	48,670	82	551	2 5	1370	840	2 12"	41,530	18' 6-3/8"	6' 2-1/4"	7' 7-7/8"	22-1/4"	6-7/8"
eco-ATC-H 10-3M24-U22	518	349	2 30	139,600	37,170	13,330	47,320	77	531	2 5	1370	840	2 12"	40,180	18' 6-3/8"	6' 2-1/4"	7' 7-7/8"	22-1/4"	5-1/2"
eco-ATC-H 10-3M24-U34	520	397	2 30	135,300	38,590	14,040	48,770	82	551	2 5	1370	840	2 12"	41,630	18' 6-3/8"	6' 2-1/4"	7' 7-7/8"	22-1/4"	6-7/8"
eco-ATC-H 10-4I24-U22	448	291	2 10	102,500	41,830	15,930	52,140	98	686	2 5	1370	840	2 12"	45,000	19' 2-7/8"	6' 2-1/4"	8' 4-3/8"	30-3/4"	5-1/2"
eco-ATC-H 10-4I24-U34	450	317	2 10	100,600	43,250	16,640	53,590	104	705	2 5	1370	840	2 12"	46,450	19' 2-7/8"	6' 2-1/4"	8' 4-3/8"	30-3/4"	6-7/8"
eco-ATC-H 10-4J24-U22	493	319	2 15	115,800	42,090	15,930	52,400	98	686	2 5	1370	840	2 12"	45,260	19' 2-7/8"	6' 2-1/4"	8' 4-3/8"	30-3/4"	5-1/2"
eco-ATC-H 10-4J24-U34	495	351	2 15	113,300	43,510	16,640	53,850	104	705	2 5	1370	840	2 12"	46,710	19' 2-7/8"	6' 2-1/4"	8' 4-3/8"	30-3/4"	6-7/8"
eco-ATC-H 10-4K24-U22	526	338	2 20	125,100	42,210	15,930	52,520	98	686	2 5	1370	840	2 12"	45,380	19' 2-7/8"	6' 2-1/4"	8' 4-3/8"	30-3/4"	5-1/2"
eco-ATC-H 10-4K24-U34	528	373	2 20	122,200	43,630	16,640	53,970	104	705	2 5	1370	840	2 12"	46,830	19' 2-7/8"	6' 2-1/4"	8' 4-3/8"	30-3/4"	6-7/8"
eco-ATC-H 10-4L24-U22	554	352	2 25	132,200	42,270	15,930	52,580	98	686	2 5	1370	840	2 12"	45,440	19' 2-7/8"	6' 2-1/4"	8' 4-3/8"	30-3/4"	5-1/2"
eco-ATC-H 10-4L24-U34	554	390	2 25	128,800	43,690	16,640	54,030	104	705	2 5	1370	840	2 12"	46,890	19' 2-7/8"	6' 2-1/4"	8' 4-3/8"	30-3/4"	6-7/8"
eco-ATC-H 10-4M24-U22	577	364	2 30	138,200	42,370	15,930	52,680	98	686	2 5	1370	840	2 12"	45,540	19' 2-7/8"	6' 2-1/4"	8' 4-3/8"	30-3/4"	5-1/2"
eco-ATC-H 10-4M24-U34	577	404	2 30	134,500	43,790	16,640	54,130	104	705	2 5	1370	840	2 12"	46,990	19' 2-7/8"	6' 2-1/4"	8' 4-3/8"	30-3/4"	6-7/8"

* Tons at standard conditions: 96.3°F condensing, 20°F suction and 78°F W.B.

** Gallons shown is water in suspension in unit and piping. Allow for additional water in bottom of remote sump to cover pump suction and strainer during operation. (12" would normally be sufficient.)

† Heaviest section is the coil section.

Dimensions are subject to change. Do not use for pre-fabrication. Quantity of coil connections subject to change based on refrigerant and design conditions.

NOTE: Interconnecting piping between ARID *fin Pak*™ Dry Coil outlets and Ellipti-*fin*® Coil inlets are field installed and tested (by others).

Engineering Dimensions & Data

eco-ATC-H 10-2I36-U22 to eco-ATC-H 10-4N36-U34

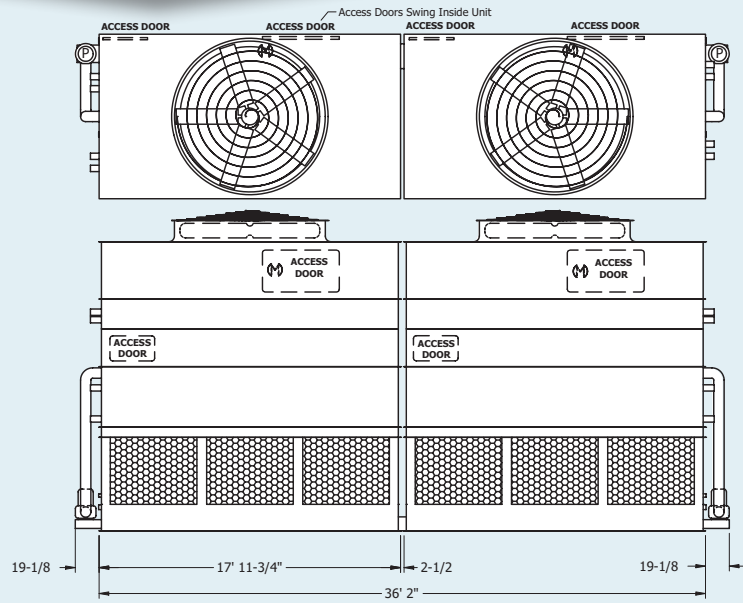
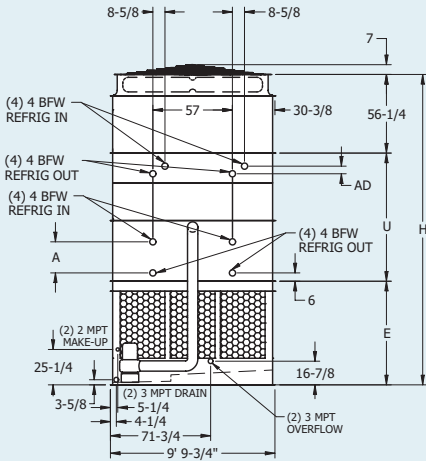

Table 11 Engineering Data

Model No.	R-717 Tons ²		Fans		Weights ¹			Coil Volume (ft. ³)	NH ₃ Op. Charge (lbs.)	Spray Pump		Remote Sump			Dimensions (ft)			Dimensions (in)	
	Wet Capacity	Dry Capacity @ 50°F DB Switch Point	HP	CFM	Shipping	Heaviest Section†	Operating			HP	GPM	Gallons Req'd ^{2a}	Conn. Size	Operating Weight (lbs)	Height H	Lower E	Middle U	Wet Coil A	Dry Coil AD
eco-ATC-H 10-2I36-U22	476	369	2 10	140,800	44,570	15,520	59,720	83	554	2 7.5	2060	1260	2 12"	49,220	17' 9-7/8"	6' 2-1/4"	6' 11-3/8"	13-3/4"	5-1/2"
eco-ATC-H 10-2I36-U34	483	426	2 10	137,800	46,730	16,600	61,910	90	580	2 7.5	2060	1260	2 12"	51,410	17' 9-7/8"	6' 2-1/4"	6' 11-3/8"	13-3/4"	6-7/8"
eco-ATC-H 10-2I36-U22	522	404	2 15	158,800	44,830	15,520	59,980	83	554	2 7.5	2060	1260	2 12"	49,480	17' 9-7/8"	6' 2-1/4"	6' 11-3/8"	13-3/4"	5-1/2"
eco-ATC-H 10-2I36-U34	529	468	2 15	154,700	46,990	16,600	62,170	90	580	2 7.5	2060	1260	2 12"	51,670	17' 9-7/8"	6' 2-1/4"	6' 11-3/8"	13-3/4"	6-7/8"
eco-ATC-H 10-2K36-U22	557	430	2 20	172,600	44,950	15,520	60,100	83	554	2 7.5	2060	1260	2 12"	49,600	17' 9-7/8"	6' 2-1/4"	6' 11-3/8"	13-3/4"	5-1/2"
eco-ATC-H 10-2K36-U34	564	500	2 20	167,800	47,110	16,600	62,290	90	580	2 7.5	2060	1260	2 12"	51,790	17' 9-7/8"	6' 2-1/4"	6' 11-3/8"	13-3/4"	6-7/8"
eco-ATC-H 10-2L36-U22	585	450	2 25	183,900	45,010	15,520	60,160	83	554	2 7.5	2060	1260	2 12"	49,660	17' 9-7/8"	6' 2-1/4"	6' 11-3/8"	13-3/4"	5-1/2"
eco-ATC-H 10-2L36-U34	592	525	2 25	178,500	47,170	16,600	62,350	90	580	2 7.5	2060	1260	2 12"	51,850	17' 9-7/8"	6' 2-1/4"	6' 11-3/8"	13-3/4"	6-7/8"
eco-ATC-H 10-2M36-U22	609	465	2 30	192,200	45,110	15,520	60,260	83	554	2 7.5	2060	1260	2 12"	49,760	17' 9-7/8"	6' 2-1/4"	6' 11-3/8"	13-3/4"	5-1/2"
eco-ATC-H 10-2M36-U34	615	543	2 30	186,300	47,270	16,600	62,450	90	580	2 7.5	2060	1260	2 12"	51,950	17' 9-7/8"	6' 2-1/4"	6' 11-3/8"	13-3/4"	6-7/8"
eco-ATC-H 10-2N36-U22	648	489	2 40	205,700	45,430	15,520	60,580	83	554	2 7.5	2060	1260	2 12"	50,080	17' 9-7/8"	6' 2-1/4"	6' 11-3/8"	13-3/4"	5-1/2"
eco-ATC-H 10-2N36-U34	653	572	2 40	198,900	47,590	16,600	62,770	90	580	2 7.5	2060	1260	2 12"	52,270	17' 9-7/8"	6' 2-1/4"	6' 11-3/8"	13-3/4"	6-7/8"
eco-ATC-H 10-3I36-U22	555	388	2 10	139,100	52,150	19,310	67,540	115	788	2 7.5	2060	1260	2 12"	57,040	18' 6-3/8"	6' 2-1/4"	7' 7-7/8"	22-1/4"	5-1/2"
eco-ATC-H 10-3I36-U34	561	432	2 10	136,600	54,310	20,390	69,730	122	814	2 7.5	2060	1260	2 12"	59,230	18' 6-3/8"	6' 2-1/4"	7' 7-7/8"	22-1/4"	6-7/8"
eco-ATC-H 10-3I36-U22	611	426	2 15	157,300	52,410	19,310	67,800	115	788	2 7.5	2060	1260	2 12"	57,300	18' 6-3/8"	6' 2-1/4"	7' 7-7/8"	22-1/4"	5-1/2"
eco-ATC-H 10-3I36-U34	617	477	2 15	154,000	54,570	20,390	69,990	122	814	2 7.5	2060	1260	2 12"	59,490	18' 6-3/8"	6' 2-1/4"	7' 7-7/8"	22-1/4"	6-7/8"
eco-ATC-H 10-3K36-U22	653	454	2 20	171,300	52,530	19,310	67,920	115	788	2 7.5	2060	1260	2 12"	57,420	18' 6-3/8"	6' 2-1/4"	7' 7-7/8"	22-1/4"	5-1/2"
eco-ATC-H 10-3K36-U34	658	512	2 20	167,300	54,690	20,390	70,110	122	814	2 7.5	2060	1260	2 12"	59,610	18' 6-3/8"	6' 2-1/4"	7' 7-7/8"	22-1/4"	6-7/8"
eco-ATC-H 10-3L36-U22	688	477	2 25	183,000	52,590	19,310	67,980	115	788	2 7.5	2060	1260	2 12"	57,480	18' 6-3/8"	6' 2-1/4"	7' 7-7/8"	22-1/4"	5-1/2"
eco-ATC-H 10-3L36-U34	692	539	2 25	178,300	54,750	20,390	70,170	122	814	2 7.5	2060	1260	2 12"	59,670	18' 6-3/8"	6' 2-1/4"	7' 7-7/8"	22-1/4"	6-7/8"
eco-ATC-H 10-3M36-U22	716	493	2 30	191,400	52,690	19,310	68,080	115	788	2 7.5	2060	1260	2 12"	57,580	18' 6-3/8"	6' 2-1/4"	7' 7-7/8"	22-1/4"	5-1/2"
eco-ATC-H 10-3M36-U34	720	559	2 30	186,400	54,850	20,390	70,270	122	814	2 7.5	2060	1260	2 12"	59,770	18' 6-3/8"	6' 2-1/4"	7' 7-7/8"	22-1/4"	6-7/8"
eco-ATC-H 10-3N36-U22	763	519	2 40	205,200	53,010	19,310	68,400	115	788	2 7.5	2060	1260	2 12"	57,900	18' 6-3/8"	6' 2-1/4"	7' 7-7/8"	22-1/4"	5-1/2"
eco-ATC-H 10-3N36-U34	766	590	2 40	199,400	55,170	20,390	70,590	122	814	2 7.5	2060	1260	2 12"	60,090	18' 6-3/8"	6' 2-1/4"	7' 7-7/8"	22-1/4"	6-7/8"
eco-ATC-H 10-4I36-U22	613	398	2 10	136,500	59,890	23,180	75,520	147	1022	2 7.5	2060	1260	2 12"	65,020	19' 2-7/8"	6' 2-1/4"	8' 4-3/8"	30-3/4"	5-1/2"
eco-ATC-H 10-4I36-U34	617	432	2 10	134,500	62,050	24,260	77,710	154	1048	2 7.5	2060	1260	2 12"	67,210	19' 2-7/8"	6' 2-1/4"	8' 4-3/8"	30-3/4"	6-7/8"
eco-ATC-H 10-4I36-U22	676	440	2 15	154,700	60,150	23,180	75,780	147	1022	2 7.5	2060	1260	2 12"	65,280	19' 2-7/8"	6' 2-1/4"	8' 4-3/8"	30-3/4"	5-1/2"
eco-ATC-H 10-4I36-U34	680	480	2 15	152,000	62,310	24,260	77,970	154	1048	2 7.5	2060	1260	2 12"	67,470	19' 2-7/8"	6' 2-1/4"	8' 4-3/8"	30-3/4"	6-7/8"
eco-ATC-H 10-4K36-U22	723	470	2 20	168,800	60,270	23,180	75,900	147	1022	2 7.5	2060	1260	2 12"	65,400	19' 2-7/8"	6' 2-1/4"	8' 4-3/8"	30-3/4"	5-1/2"
eco-ATC-H 10-4K36-U34	727	516	2 20	165,500	62,430	24,260	78,090	154	1048	2 7.5	2060	1260	2 12"	67,590	19' 2-7/8"	6' 2-1/4"	8' 4-3/8"	30-3/4"	6-7/8"
eco-ATC-H 10-4L36-U22	762	495	2 25	180,500	60,330	23,180	75,960	147	1022	2 7.5	2060	1260	2 12"	65,460	19' 2-7/8"	6' 2-1/4"	8' 4-3/8"	30-3/4"	5-1/2"
eco-ATC-H 10-4L36-U34	765	546	2 25	176,600	62,490	24,260	78,150	154	1048	2 7.5	2060	1260	2 12"	67,650	19' 2-7/8"	6' 2-1/4"	8' 4-3/8"	30-3/4"	6-7/8"
eco-ATC-H 10-4M36-U22	795	512	2 30	189,000	60,430	23,180	76,060	147	1022	2 7.5	2060	1260	2 12"	65,560	19' 2-7/8"	6' 2-1/4"	8' 4-3/8"	30-3/4"	5-1/2"
eco-ATC-H 10-4M36-U34	797	566	2 30	184,700	62,590	24,260	78,250	154	1048	2 7.5	2060	1260	2 12"	67,750	19' 2-7/8"	6' 2-1/4"	8' 4-3/8"	30-3/4"	6-7/8"
eco-ATC-H 10-4N36-U22	848	540	2 40	203,000	60,750	23,180	76,380	147	1022	2 7.5	2060	1260	2 12"	65,880	19' 2-7/8"	6' 2-1/4"	8' 4-3/8"	30-3/4"	5-1/2"
eco-ATC-H 10-4N36-U34	850	600	2 40	197,900	62,910	24,260	78,570	154	1048	2 7.5	2060	1260	2 12"	68,070	19' 2-7/8"	6' 2-1/4"	8' 4-3/8"	30-3/4"	6-7/8"

* Tons at standard conditions: 96.3°F condensing, 20°F suction and 78°F W.B.
 ** Gallons shown is water in suspension in unit and piping. Allow for additional water in bottom of remote sump to cover pump suction and strainer during operation. (12" would normally be sufficient.)
 † Heaviest section is the coil section.
 Dimensions are subject to change. Do not use for pre-fabrication. Quantity of coil connections subject to change based on refrigerant and design conditions.
 NOTE: Interconnecting piping between ARID *fin Pak*™ Dry Coil outlets and Ellipti-*fin*® Coil inlets are field installed and tested (by others).

Engineering Dimensions & Data

eco-ATC-H 12-2J12-U22 to eco-ATC-H 12-4N12-U34

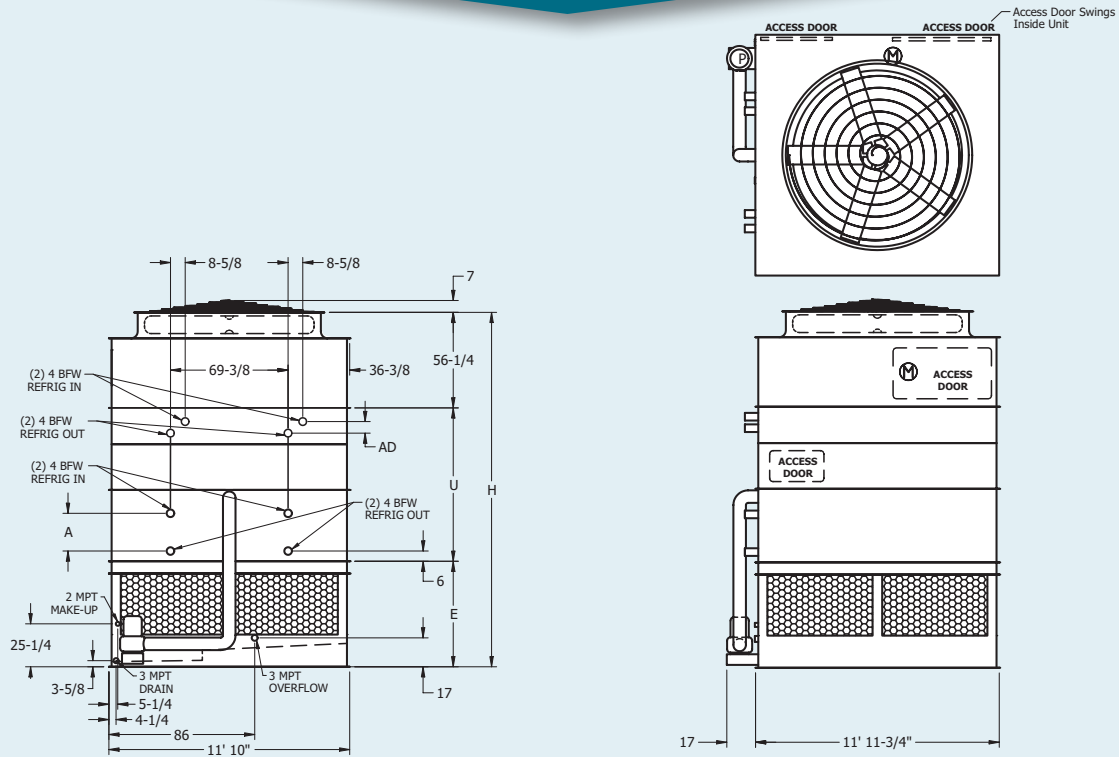

Table 12 Engineering Data

Model No.	R-717 Tons*		Fans		Weights†			Coil Volume (ft.)	NH ₃ Op. Charge (lbs.)	Spray Pump		Remote Sump		Dimensions (ft)			Dimensions (in)		
	Wet Capacity	Dry Capacity @ 50°F DB Switch Point	HP	CFM	Shipping	Heaviest Section†	Operating			HP	GPM	Gallons Req'd**	Conn. Size	Operating Weight (lbs)	Height H	Lower E	Middle U	Wet Coil A	Dry Coil AD
eco-ATC-H 12-2J12-U22	253	188	15	67,500	17,930	12,380	23,750	35	232	5	800	490	12"	19,800	16' 9-7/8"	5' 2-1/4"	6' 11-3/8"	13-3/4"	5-1/2"
eco-ATC-H 12-2J12-U34	254	204	15	65,600	18,800	13,250	24,630	38	243	5	800	490	12"	20,680	16' 9-7/8"	5' 2-1/4"	6' 11-3/8"	13-3/4"	6-7/8"
eco-ATC-H 12-2K12-U22	270	200	20	73,300	17,990	12,380	23,810	35	232	5	800	490	12"	19,860	16' 9-7/8"	5' 2-1/4"	6' 11-3/8"	13-3/4"	5-1/2"
eco-ATC-H 12-2K12-U34	270	218	20	71,000	18,860	13,250	24,690	38	243	5	800	490	12"	20,740	16' 9-7/8"	5' 2-1/4"	6' 11-3/8"	13-3/4"	6-7/8"
eco-ATC-H 12-2L12-U22	283	208	25	77,300	18,020	12,380	23,840	35	232	5	800	490	12"	19,890	16' 9-7/8"	5' 2-1/4"	6' 11-3/8"	13-3/4"	5-1/2"
eco-ATC-H 12-2L12-U34	283	228	25	74,800	18,890	13,250	24,720	38	243	5	800	490	12"	20,770	16' 9-7/8"	5' 2-1/4"	6' 11-3/8"	13-3/4"	6-7/8"
eco-ATC-H 12-2M12-U22	294	215	30	80,700	18,070	12,380	23,890	35	232	5	800	490	12"	19,940	16' 9-7/8"	5' 2-1/4"	6' 11-3/8"	13-3/4"	5-1/2"
eco-ATC-H 12-2M12-U34	294	236	30	77,900	18,940	13,250	24,770	38	243	5	800	490	12"	20,820	16' 9-7/8"	5' 2-1/4"	6' 11-3/8"	13-3/4"	6-7/8"
eco-ATC-H 12-3J12-U22	298	199	15	67,100	21,080	15,530	27,000	48	328	5	800	490	12"	23,050	17' 6-3/8"	5' 2-1/4"	7' 7-7/8"	22-1/4"	5-1/2"
eco-ATC-H 12-3J12-U34	298	209	15	65,500	21,950	16,400	27,880	51	339	5	800	490	12"	23,930	17' 6-3/8"	5' 2-1/4"	7' 7-7/8"	22-1/4"	6-7/8"
eco-ATC-H 12-3K12-U22	318	213	20	73,000	21,140	15,530	27,060	48	328	5	800	490	12"	23,110	17' 6-3/8"	5' 2-1/4"	7' 7-7/8"	22-1/4"	5-1/2"
eco-ATC-H 12-3K12-U34	317	225	20	71,100	22,010	16,400	27,940	51	339	5	800	490	12"	23,990	17' 6-3/8"	5' 2-1/4"	7' 7-7/8"	22-1/4"	6-7/8"
eco-ATC-H 12-3L12-U22	334	223	25	77,100	21,170	15,530	27,090	48	328	5	800	490	12"	23,140	17' 6-3/8"	5' 2-1/4"	7' 7-7/8"	22-1/4"	5-1/2"
eco-ATC-H 12-3L12-U34	333	236	25	75,000	22,040	16,400	27,970	51	339	5	800	490	12"	24,020	17' 6-3/8"	5' 2-1/4"	7' 7-7/8"	22-1/4"	6-7/8"
eco-ATC-H 12-3M12-U22	348	230	30	80,600	21,220	15,530	27,140	48	328	5	800	490	12"	23,190	17' 6-3/8"	5' 2-1/4"	7' 7-7/8"	22-1/4"	5-1/2"
eco-ATC-H 12-3M12-U34	346	244	30	78,200	22,090	16,400	28,020	51	339	5	800	490	12"	24,070	17' 6-3/8"	5' 2-1/4"	7' 7-7/8"	22-1/4"	6-7/8"
eco-ATC-H 12-3N12-U22	371	243	40	86,300	21,380	15,530	27,300	48	328	5	800	490	12"	23,350	17' 6-3/8"	5' 2-1/4"	7' 7-7/8"	22-1/4"	5-1/2"
eco-ATC-H 12-3N12-U34	368	258	40	83,500	22,250	16,400	28,180	51	339	5	800	490	12"	24,230	17' 6-3/8"	5' 2-1/4"	7' 7-7/8"	22-1/4"	6-7/8"
eco-ATC-H 12-4J12-U22	331	205	15	66,200	24,270	18,720	30,290	61	423	5	800	490	12"	26,340	18' 2-7/8"	5' 2-1/4"	8' 4-3/8"	30-3/4"	5-1/2"
eco-ATC-H 12-4J12-U34	329	210	15	64,800	25,140	19,590	31,170	64	434	5	800	490	12"	27,220	18' 2-7/8"	5' 2-1/4"	8' 4-3/8"	30-3/4"	6-7/8"
eco-ATC-H 12-4K12-U22	353	220	20	72,100	24,330	18,720	30,350	61	423	5	800	490	12"	26,400	18' 2-7/8"	5' 2-1/4"	8' 4-3/8"	30-3/4"	5-1/2"
eco-ATC-H 12-4K12-U34	352	227	20	70,400	25,200	19,590	31,230	64	434	5	800	490	12"	27,280	18' 2-7/8"	5' 2-1/4"	8' 4-3/8"	30-3/4"	6-7/8"
eco-ATC-H 12-4L12-U22	372	231	25	76,300	24,360	18,720	30,380	61	423	5	800	490	12"	26,430	18' 2-7/8"	5' 2-1/4"	8' 4-3/8"	30-3/4"	5-1/2"
eco-ATC-H 12-4L12-U34	369	239	25	74,400	25,230	19,590	31,260	64	434	5	800	490	12"	27,310	18' 2-7/8"	5' 2-1/4"	8' 4-3/8"	30-3/4"	6-7/8"
eco-ATC-H 12-4M12-U22	387	239	30	79,800	24,410	18,720	30,430	61	423	5	800	490	12"	26,480	18' 2-7/8"	5' 2-1/4"	8' 4-3/8"	30-3/4"	5-1/2"
eco-ATC-H 12-4M12-U34	385	248	30	77,700	25,280	19,590	31,310	64	434	5	800	490	12"	27,360	18' 2-7/8"	5' 2-1/4"	8' 4-3/8"	30-3/4"	6-7/8"
eco-ATC-H 12-4N12-U22	413	253	40	85,500	24,570	18,720	30,590	61	423	5	800	490	12"	26,640	18' 2-7/8"	5' 2-1/4"	8' 4-3/8"	30-3/4"	5-1/2"
eco-ATC-H 12-4N12-U34	410	263	40	83,100	25,440	19,590	31,470	64	434	5	800	490	12"	27,520	18' 2-7/8"	5' 2-1/4"	8' 4-3/8"	30-3/4"	6-7/8"

* Tons at standard conditions: 96.3°F condensing, 20°F suction and 78°F W.B.

** Gallons shown is water in suspension in unit and piping. Allow for additional water in bottom of remote sump to cover pump suction and strainer during operation. (12" would normally be sufficient.)

† Heaviest section is the coil section.

Dimensions are subject to change. Do not use for pre-fabrication. Quantity of coil connections subject to change based on refrigerant and design conditions.

NOTE: Interconnecting piping between ARID *fin Pak*™ Dry Coil outlets and Ellipti-*fin*™ Coil inlets are field installed and tested (by others).

Engineering Dimensions & Data

eco-ATC-H 12-2K14-U22 to eco-ATC-H 12-4N14-U34

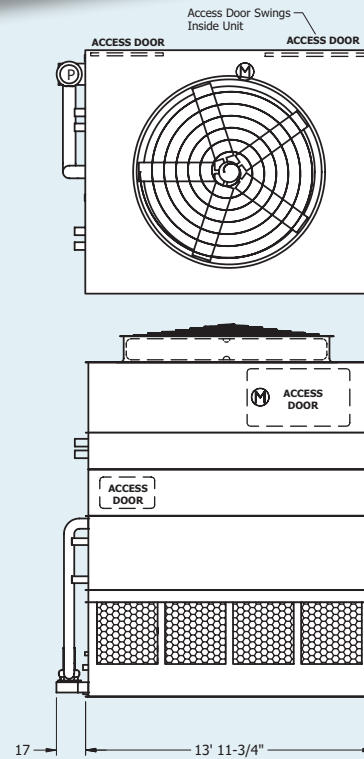
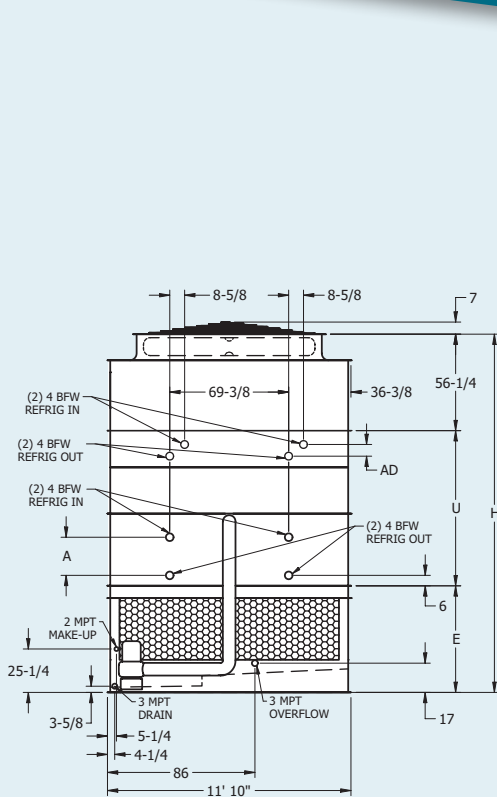

Table 13 Engineering Data

Model No.	R-717 Tons*		Fans		Weights†		Coil Volume (ft.)	NH3 Op. Charge (lbs.)	Spray Pump		Remote Sump			Dimensions (ft)			Dimensions (in)		
	Wet Capacity	Dry Capacity @ 50°F DB Switch Point	HP	CFM	Shipping	Heaviest Section†			Operating	HP	GPM	Gallons Req'd**	Conn. Size	Operating Weight (lbs)	Height H	Lower E	Middle U	Wet Coil A	Dry Coil AD
eco-ATC-H 12-2K14-U22	304	226	20	82,000	20,260	14,030	27,130	40	268	5	900	570	12"	22,560	17' 3-7/8"	5' 8-1/4"	6' 11-3/8"	13-3/4"	5-1/2"
eco-ATC-H 12-2K14-U34	305	246	20	79,500	21,290	15,060	28,180	44	281	5	900	570	12"	23,610	17' 3-7/8"	5' 8-1/4"	6' 11-3/8"	13-3/4"	6-7/8"
eco-ATC-H 12-2L14-U22	320	237	25	87,100	20,290	14,030	27,160	40	268	5	900	570	12"	22,590	17' 3-7/8"	5' 8-1/4"	6' 11-3/8"	13-3/4"	5-1/2"
eco-ATC-H 12-2L14-U34	320	259	25	84,400	21,320	15,060	28,210	44	281	5	900	570	12"	23,640	17' 3-7/8"	5' 8-1/4"	6' 11-3/8"	13-3/4"	6-7/8"
eco-ATC-H 12-2M14-U22	333	245	30	90,900	20,340	14,030	27,210	40	268	5	900	570	12"	22,640	17' 3-7/8"	5' 8-1/4"	6' 11-3/8"	13-3/4"	5-1/2"
eco-ATC-H 12-2M14-U34	333	268	30	88,000	21,370	15,060	28,260	44	281	5	900	570	12"	23,690	17' 3-7/8"	5' 8-1/4"	6' 11-3/8"	13-3/4"	6-7/8"
eco-ATC-H 12-2N14-U22	354	257	40	97,200	20,500	14,030	27,370	40	268	5	900	570	12"	22,800	17' 3-7/8"	5' 8-1/4"	6' 11-3/8"	13-3/4"	5-1/2"
eco-ATC-H 12-2N14-U34	353	283	40	93,900	21,530	15,060	28,420	44	281	5	900	570	12"	23,850	17' 3-7/8"	5' 8-1/4"	6' 11-3/8"	13-3/4"	6-7/8"
eco-ATC-H 12-3K14-U22	359	241	20	81,500	24,010	17,780	30,990	55	380	5	900	570	12"	26,420	18' 3/8"	5' 8-1/4"	7' 7-7/8"	22-1/4"	5-1/2"
eco-ATC-H 12-3K14-U34	358	253	20	79,500	25,040	18,810	32,040	59	393	5	900	570	12"	27,470	18' 3/8"	5' 8-1/4"	7' 7-7/8"	22-1/4"	6-7/8"
eco-ATC-H 12-3L14-U22	377	253	25	86,800	24,040	17,780	31,020	55	380	5	900	570	12"	26,450	18' 3/8"	5' 8-1/4"	7' 7-7/8"	22-1/4"	5-1/2"
eco-ATC-H 12-3L14-U34	376	267	25	84,500	25,070	18,810	32,070	59	393	5	900	570	12"	27,500	18' 3/8"	5' 8-1/4"	7' 7-7/8"	22-1/4"	6-7/8"
eco-ATC-H 12-3M14-U22	393	262	30	90,700	24,090	17,780	31,070	55	380	5	900	570	12"	26,500	18' 3/8"	5' 8-1/4"	7' 7-7/8"	22-1/4"	5-1/2"
eco-ATC-H 12-3M14-U34	391	277	30	88,100	25,120	18,810	32,120	59	393	5	900	570	12"	27,550	18' 3/8"	5' 8-1/4"	7' 7-7/8"	22-1/4"	6-7/8"
eco-ATC-H 12-3N14-U22	418	276	40	97,200	24,250	17,780	31,230	55	380	5	900	570	12"	26,660	18' 3/8"	5' 8-1/4"	7' 7-7/8"	22-1/4"	5-1/2"
eco-ATC-H 12-3N14-U34	416	293	40	94,200	25,280	18,810	32,280	59	393	5	900	570	12"	27,710	18' 3/8"	5' 8-1/4"	7' 7-7/8"	22-1/4"	6-7/8"
eco-ATC-H 12-4K14-U22	398	248	20	80,400	27,730	21,500	34,820	71	492	5	900	570	12"	30,250	18' 8-7/8"	5' 8-1/4"	8' 4-3/8"	30-3/4"	5-1/2"
eco-ATC-H 12-4K14-U34	396	255	20	78,700	28,760	22,530	35,870	74	505	5	900	570	12"	31,300	18' 8-7/8"	5' 8-1/4"	8' 4-3/8"	30-3/4"	6-7/8"
eco-ATC-H 12-4L14-U22	419	262	25	85,800	27,760	21,500	34,850	71	492	5	900	570	12"	30,280	18' 8-7/8"	5' 8-1/4"	8' 4-3/8"	30-3/4"	5-1/2"
eco-ATC-H 12-4L14-U34	417	270	25	83,700	28,790	22,530	35,900	74	505	5	900	570	12"	31,330	18' 8-7/8"	5' 8-1/4"	8' 4-3/8"	30-3/4"	6-7/8"
eco-ATC-H 12-4M14-U22	437	271	30	89,700	27,810	21,500	34,900	71	492	5	900	570	12"	30,330	18' 8-7/8"	5' 8-1/4"	8' 4-3/8"	30-3/4"	5-1/2"
eco-ATC-H 12-4N14-U34	434	280	30	87,500	28,840	22,530	35,950	74	505	5	900	570	12"	31,380	18' 8-7/8"	5' 8-1/4"	8' 4-3/8"	30-3/4"	6-7/8"
eco-ATC-H 12-4N14-U22	466	287	40	96,200	27,970	21,500	35,060	71	492	5	900	570	12"	30,490	18' 8-7/8"	5' 8-1/4"	8' 4-3/8"	30-3/4"	5-1/2"
eco-ATC-H 12-4N14-U34	463	298	40	93,700	29,000	22,530	36,110	74	505	5	900	570	12"	31,540	18' 8-7/8"	5' 8-1/4"	8' 4-3/8"	30-3/4"	6-7/8"

* Tons at standard conditions: 96.3°F condensing, 20°F suction and 78°F W.B.

** Gallons shown is water in suspension in unit and piping. Allow for additional water in bottom of remote sump to cover pump suction and strainer during operation. (12" would normally be sufficient.)

† Heaviest section is the coil section.

‡ Dimensions are subject to change. Do not use for pre-fabrication. Quantity of coil connections subject to change based on refrigerant and design conditions.

NOTE: Interconnecting piping between ARID *fin Pak*™ Dry Coil outlets and Ellipti-*fin*® Coil inlets are field installed and tested (by others).

Engineering Dimensions & Data

eco-ATC-H 12-2K18-U22 to eco-ATC-H 12-4O18-U34

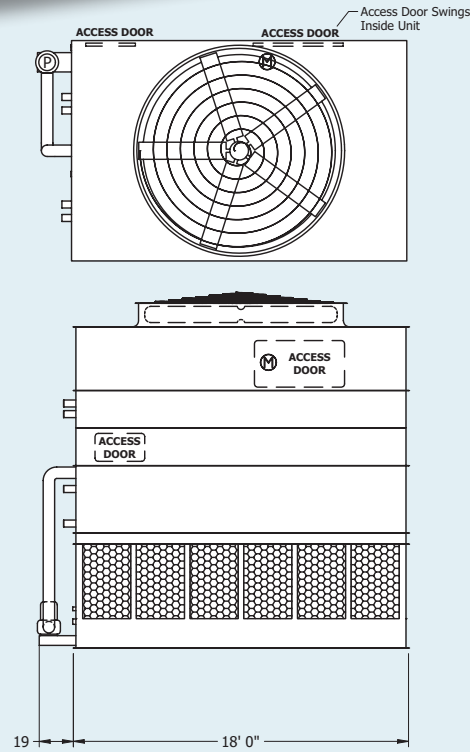
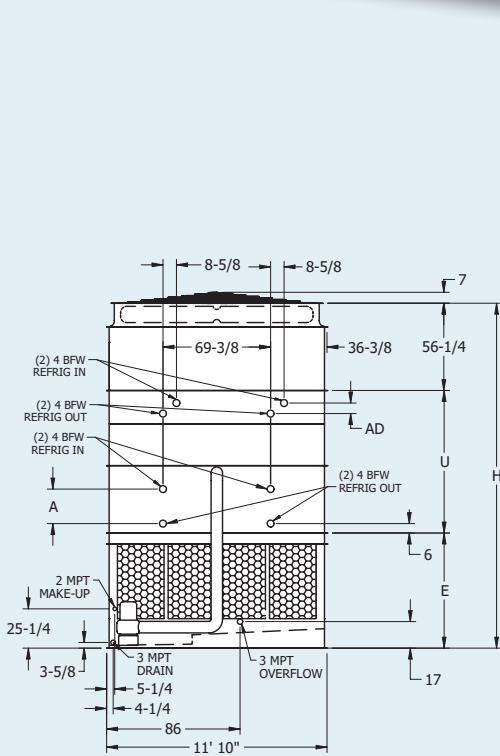

Table 14 Engineering Data

Model No.	R-717 Tons ^c		Fans		Weights [†]			Coil Volume (ft ³)	NH ₃ Op. Charge (lbs.)	Spray Pump		Remote Sump		Dimensions (ft)			Dimensions (in)		
	Wet Capacity	Dry Capacity @ 50°F DB Switch Point	HP	CFM	Shipping	Heaviest Section [†]	Operating			HP	GPM	Gallons Req'd ^{***}	Conn. Size	Operating Weight (lbs)	Height H	Lower E	Middle U	Wet Coil A	Dry Coil AD
eco-ATC-H 12-2K18-U22	373	283	20	101,400	25,410	17,820	34,110	51	341	7.5	1200	720	12"	28,240	17'-9-7/8"	6'-2-1/4"	6'-11-3/8"	13-3/4"	5-1/2"
eco-ATC-H 12-2K18-U34	375	308	20	98,600	26,740	19,140	35,450	56	358	7.5	1200	720	12"	29,580	17'-9-7/8"	6'-2-1/4"	6'-11-3/8"	13-3/4"	6-7/8"
eco-ATC-H 12-2L18-U22	392	297	25	108,000	25,440	17,820	34,140	51	341	7.5	1200	720	12"	28,270	17'-9-7/8"	6'-2-1/4"	6'-11-3/8"	13-3/4"	5-1/2"
eco-ATC-H 12-2L18-U34	393	325	25	104,900	26,770	19,140	35,480	56	358	7.5	1200	720	12"	29,610	17'-9-7/8"	6'-2-1/4"	6'-11-3/8"	13-3/4"	6-7/8"
eco-ATC-H 12-2M18-U22	408	309	30	113,800	25,490	17,820	34,190	51	341	7.5	1200	720	12"	28,320	17'-9-7/8"	6'-2-1/4"	6'-11-3/8"	13-3/4"	5-1/2"
eco-ATC-H 12-2M18-U34	409	339	30	110,300	26,820	19,140	35,530	56	358	7.5	1200	720	12"	29,660	17'-9-7/8"	6'-2-1/4"	6'-11-3/8"	13-3/4"	6-7/8"
eco-ATC-H 12-2N18-U22	434	325	40	121,900	25,650	17,820	34,350	51	341	7.5	1200	720	12"	28,480	17'-9-7/8"	6'-2-1/4"	6'-11-3/8"	13-3/4"	5-1/2"
eco-ATC-H 12-2N18-U34	435	358	40	117,900	26,980	19,140	35,690	56	358	7.5	1200	720	12"	29,820	17'-9-7/8"	6'-2-1/4"	6'-11-3/8"	13-3/4"	6-7/8"
eco-ATC-H 12-3K18-U22	438	300	20	100,600	30,100	22,510	38,950	71	485	7.5	1200	720	12"	33,080	18'-6-3/8"	6'-2-1/4"	7'-7-7/8"	22-1/4"	5-1/2"
eco-ATC-H 12-3K18-U34	438	315	20	98,300	31,430	23,830	40,290	75	502	7.5	1200	720	12"	34,420	18'-6-3/8"	6'-2-1/4"	7'-7-7/8"	22-1/4"	6-7/8"
eco-ATC-H 12-3L18-U22	461	316	25	107,400	30,130	22,510	38,980	71	485	7.5	1200	720	12"	33,110	18'-6-3/8"	6'-2-1/4"	7'-7-7/8"	22-1/4"	5-1/2"
eco-ATC-H 12-3L18-U34	461	334	25	104,800	31,460	23,830	40,320	75	502	7.5	1200	720	12"	34,450	18'-6-3/8"	6'-2-1/4"	7'-7-7/8"	22-1/4"	6-7/8"
eco-ATC-H 12-3M18-U22	480	330	30	113,300	30,180	22,510	39,030	71	485	7.5	1200	720	12"	33,160	18'-6-3/8"	6'-2-1/4"	7'-7-7/8"	22-1/4"	5-1/2"
eco-ATC-H 12-3M18-U34	480	349	30	110,300	31,510	23,830	40,370	75	502	7.5	1200	720	12"	34,500	18'-6-3/8"	6'-2-1/4"	7'-7-7/8"	22-1/4"	6-7/8"
eco-ATC-H 12-3N18-U22	512	349	40	121,600	30,340	22,510	39,190	71	485	7.5	1200	720	12"	33,320	18'-6-3/8"	6'-2-1/4"	7'-7-7/8"	22-1/4"	5-1/2"
eco-ATC-H 12-3N18-U34	511	370	40	118,100	31,670	23,830	40,530	75	502	7.5	1200	720	12"	34,660	18'-6-3/8"	6'-2-1/4"	7'-7-7/8"	22-1/4"	6-7/8"
eco-ATC-H 12-3O18-U22	538	363	50	128,300	30,350	22,510	39,200	71	485	7.5	1200	720	12"	33,330	18'-6-3/8"	6'-2-1/4"	7'-7-7/8"	22-1/4"	5-1/2"
eco-ATC-H 12-3N18-U34	511	370	50	118,100	31,680	23,830	40,540	75	502	7.5	1200	720	12"	34,670	18'-6-3/8"	6'-2-1/4"	7'-7-7/8"	22-1/4"	6-7/8"
eco-ATC-H 12-4K18-U22	485	308	20	99,100	34,850	27,260	43,840	90	629	7.5	1200	720	12"	37,970	19'-2-7/8"	6'-2-1/4"	8'-4-3/8"	30-3/4"	5-1/2"
eco-ATC-H 12-4K18-U34	484	316	20	97,200	36,180	28,580	45,180	95	646	7.5	1200	720	12"	39,310	19'-2-7/8"	6'-2-1/4"	8'-4-3/8"	30-3/4"	6-7/8"
eco-ATC-H 12-4L18-U22	512	326	25	106,000	34,880	27,260	43,870	90	629	7.5	1200	720	12"	38,000	19'-2-7/8"	6'-2-1/4"	8'-4-3/8"	30-3/4"	5-1/2"
eco-ATC-H 12-4L18-U34	510	336	25	103,700	36,210	28,580	45,210	95	646	7.5	1200	720	12"	39,340	19'-2-7/8"	6'-2-1/4"	8'-4-3/8"	30-3/4"	6-7/8"
eco-ATC-H 12-4M18-U22	534	341	30	111,900	34,930	27,260	43,920	90	629	7.5	1200	720	12"	38,050	19'-2-7/8"	6'-2-1/4"	8'-4-3/8"	30-3/4"	5-1/2"
eco-ATC-H 12-4M18-U34	532	352	30	109,300	36,260	28,580	45,260	95	646	7.5	1200	720	12"	39,390	19'-2-7/8"	6'-2-1/4"	8'-4-3/8"	30-3/4"	6-7/8"
eco-ATC-H 12-4N18-U22	570	361	40	120,300	35,090	27,260	44,080	90	629	7.5	1200	720	12"	38,210	19'-2-7/8"	6'-2-1/4"	8'-4-3/8"	30-3/4"	5-1/2"
eco-ATC-H 12-4N18-U34	567	375	40	117,300	36,420	28,580	45,420	95	646	7.5	1200	720	12"	39,550	19'-2-7/8"	6'-2-1/4"	8'-4-3/8"	30-3/4"	6-7/8"
eco-ATC-H 12-4O18-U22	599	378	50	127,000	35,100	27,260	44,090	90	629	7.5	1200	720	12"	38,220	19'-2-7/8"	6'-2-1/4"	8'-4-3/8"	30-3/4"	5-1/2"
eco-ATC-H 12-4O18-U34	595	393	50	123,700	36,430	28,580	45,430	95	646	7.5	1200	720	12"	39,560	19'-2-7/8"	6'-2-1/4"	8'-4-3/8"	30-3/4"	6-7/8"

* Tons at standard conditions: 96.3°F condensing, 20°F suction and 78°F W.B.

** Gallons shown is water in suspension in unit and piping. Allow for additional water in bottom of remote sump to cover pump suction and strainer during operation. (12" would normally be sufficient.)

† Heaviest section is the coil section.

Dimensions are subject to change. Do not use for pre-fabrication. Quantity of coil connections subject to change based on refrigerant and design conditions.

NOTE: Interconnecting piping between ARID *fin Pak*™ Dry Coil outlets and Ellipti-*fin*® Coil inlets are field installed and tested (by others).

Engineering Dimensions & Data

eco-ATC-H 12-2L20-U22 to eco-ATC-H 12-4P20-U34

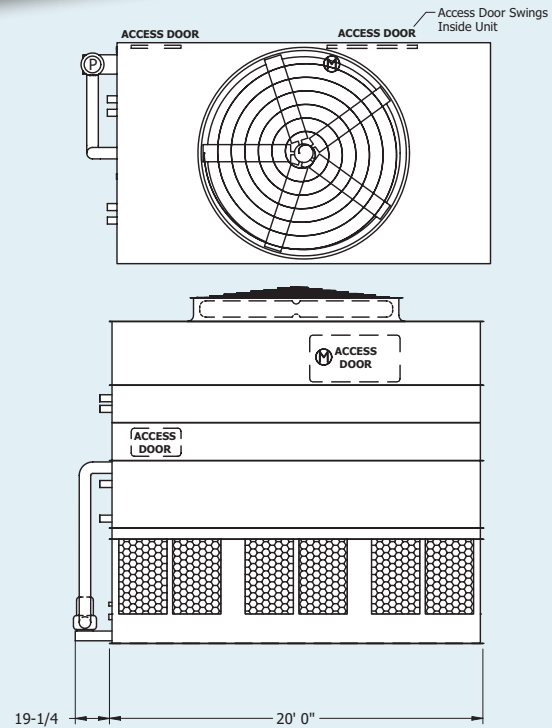
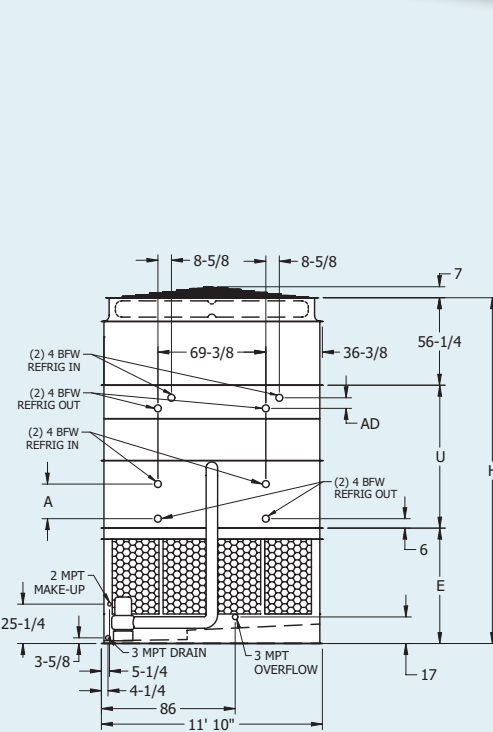

Table 15 Engineering Data

Model No.	R-717 Tons [†]		Fans		Weights [†]			Coil Volume (ft.)	NH3 Op. Charge (lbs.)	Spray Pump		Remote Sump			Dimensions (ft)			Dimensions (in)	
	Wet Capacity	Dry Capacity @ 50°F DB Switch Point	HP	CFM	Shipping	Heaviest Section [†]	Operating			HP	GPM	Gallons Req'd ^{**}	Conn. Size	Operating Weight (lbs)	Height H	Lower E	Middle U	Wet Coil A	Dry Coil AD
eco-ATC-H 12-2L20-U22	426	318	25	116,700	27,860	19,460	37,680	57	378	10	1400	800	14"	30,980	17'9-7/8"	6'2-1/4"	6'11-3/8"	13-3/4"	5-1/2"
eco-ATC-H 12-2L20-U34	428	351	25	113,400	29,340	20,940	39,170	62	396	10	1400	800	14"	32,470	17'9-7/8"	6'2-1/4"	6'11-3/8"	13-3/4"	6-7/8"
eco-ATC-H 12-2M20-U22	443	331	30	122,900	27,910	19,460	37,730	57	378	10	1400	800	14"	31,030	17'9-7/8"	6'2-1/4"	6'11-3/8"	13-3/4"	5-1/2"
eco-ATC-H 12-2M20-U34	445	366	30	119,300	29,390	20,940	39,220	62	396	10	1400	800	14"	32,520	17'9-7/8"	6'2-1/4"	6'11-3/8"	13-3/4"	6-7/8"
eco-ATC-H 12-2N20-U22	472	350	40	132,400	28,070	19,460	37,890	57	378	10	1400	800	14"	31,190	17'9-7/8"	6'2-1/4"	6'11-3/8"	13-3/4"	5-1/2"
eco-ATC-H 12-2N20-U34	473	388	40	128,200	29,550	20,940	39,380	62	396	10	1400	800	14"	32,680	17'9-7/8"	6'2-1/4"	6'11-3/8"	13-3/4"	6-7/8"
eco-ATC-H 12-2O20-U22	495	363	50	139,500	28,080	19,460	37,900	57	378	10	1400	800	14"	31,200	17'9-7/8"	6'2-1/4"	6'11-3/8"	13-3/4"	5-1/2"
eco-ATC-H 12-2O20-U34	496	405	50	134,900	29,560	20,940	39,390	62	396	10	1400	800	14"	32,690	17'9-7/8"	6'2-1/4"	6'11-3/8"	13-3/4"	6-7/8"
eco-ATC-H 12-3L20-U22	501	338	25	115,900	33,160	24,760	43,140	78	538	10	1400	800	14"	36,440	18'6-3/8"	6'2-1/4"	7'7-7/8"	22-1/4"	5-1/2"
eco-ATC-H 12-3L20-U34	501	359	25	113,200	34,640	26,240	44,630	83	557	10	1400	800	14"	37,930	18'6-3/8"	6'2-1/4"	7'7-7/8"	22-1/4"	6-7/8"
eco-ATC-H 12-3M20-U22	522	353	30	122,300	33,210	24,760	43,190	78	538	10	1400	800	14"	36,490	18'6-3/8"	6'2-1/4"	7'7-7/8"	22-1/4"	5-1/2"
eco-ATC-H 12-3M20-U34	522	376	30	119,200	34,690	26,240	44,680	83	557	10	1400	800	14"	37,980	18'6-3/8"	6'2-1/4"	7'7-7/8"	22-1/4"	6-7/8"
eco-ATC-H 12-3N20-U22	557	374	40	132,000	33,370	24,760	43,350	78	538	10	1400	800	14"	36,650	18'6-3/8"	6'2-1/4"	7'7-7/8"	22-1/4"	5-1/2"
eco-ATC-H 12-3N20-U34	556	401	40	128,400	34,850	26,240	44,840	83	557	10	1400	800	14"	38,140	18'6-3/8"	6'2-1/4"	7'7-7/8"	22-1/4"	6-7/8"
eco-ATC-H 12-3O20-U22	585	390	50	139,300	33,380	24,760	43,360	78	538	10	1400	800	14"	36,660	18'6-3/8"	6'2-1/4"	7'7-7/8"	22-1/4"	5-1/2"
eco-ATC-H 12-3O20-U34	583	419	50	135,200	34,860	26,240	44,850	83	557	10	1400	800	14"	38,150	18'6-3/8"	6'2-1/4"	7'7-7/8"	22-1/4"	6-7/8"
eco-ATC-H 12-3P20-U22	609	403	60	145,500	33,580	24,760	43,560	78	538	10	1400	800	14"	36,860	18'6-3/8"	6'2-1/4"	7'7-7/8"	22-1/4"	5-1/2"
eco-ATC-H 12-3P20-U34	607	434	60	141,000	35,060	26,240	45,050	83	557	10	1400	800	14"	38,350	18'6-3/8"	6'2-1/4"	7'7-7/8"	22-1/4"	6-7/8"
eco-ATC-H 12-4L20-U22	555	348	25	114,200	38,400	30,000	48,540	100	699	10	1400	800	14"	41,840	19'2-7/8"	6'2-1/4"	8'4-3/8"	30-3/4"	5-1/2"
eco-ATC-H 12-4L20-U34	554	362	25	111,900	39,880	31,480	50,030	105	717	10	1400	800	14"	43,330	19'2-7/8"	6'2-1/4"	8'4-3/8"	30-3/4"	6-7/8"
eco-ATC-H 12-4M20-U22	579	364	30	120,600	38,450	30,000	48,590	100	699	10	1400	800	14"	41,890	19'2-7/8"	6'2-1/4"	8'4-3/8"	30-3/4"	5-1/2"
eco-ATC-H 12-4M20-U34	578	379	30	118,000	39,930	31,480	50,080	105	717	10	1400	800	14"	43,380	19'2-7/8"	6'2-1/4"	8'4-3/8"	30-3/4"	6-7/8"
eco-ATC-H 12-4N20-U22	619	388	40	130,400	38,610	30,000	48,750	100	699	10	1400	800	14"	42,050	19'2-7/8"	6'2-1/4"	8'4-3/8"	30-3/4"	5-1/2"
eco-ATC-H 12-4N20-U34	616	406	40	127,300	40,090	31,480	50,240	105	717	10	1400	800	14"	43,540	19'2-7/8"	6'2-1/4"	8'4-3/8"	30-3/4"	6-7/8"
eco-ATC-H 12-4O20-U22	651	405	50	137,800	38,620	30,000	48,760	100	699	10	1400	800	14"	42,060	19'2-7/8"	6'2-1/4"	8'4-3/8"	30-3/4"	5-1/2"
eco-ATC-H 12-4O20-U34	648	425	50	134,300	40,100	31,480	50,250	105	717	10	1400	800	14"	43,550	19'2-7/8"	6'2-1/4"	8'4-3/8"	30-3/4"	6-7/8"
eco-ATC-H 12-4P20-U22	678	420	60	144,100	38,820	30,000	48,960	100	699	10	1400	800	14"	42,260	19'2-7/8"	6'2-1/4"	8'4-3/8"	30-3/4"	5-1/2"
eco-ATC-H 12-4P20-U34	674	442	60	140,200	40,300	31,480	50,450	105	717	10	1400	800	14"	43,750	19'2-7/8"	6'2-1/4"	8'4-3/8"	30-3/4"	6-7/8"

* Tons at standard conditions: 96.3°F condensing, 20°F suction and 78°F W.B.

** Gallons shown is water in suspension in unit and piping. Allow for additional water in bottom of remote sump to cover pump suction and strainer during operation. (12" would normally be sufficient.)

† Heaviest section is the coil section.

Dimensions are subject to change. Do not use for pre-fabrication. Quantity of coil connections subject to change based on refrigerant and design conditions.

NOTE: Interconnecting piping between ARID *fin Pak*™ Dry Coil outlets and Ellipti-*fin*® Coil inlets are field installed and tested (by others).

Engineering Dimensions & Data

eco-ATC-H 12-2K28-U22 to eco-ATC-H 12-4N28-U34

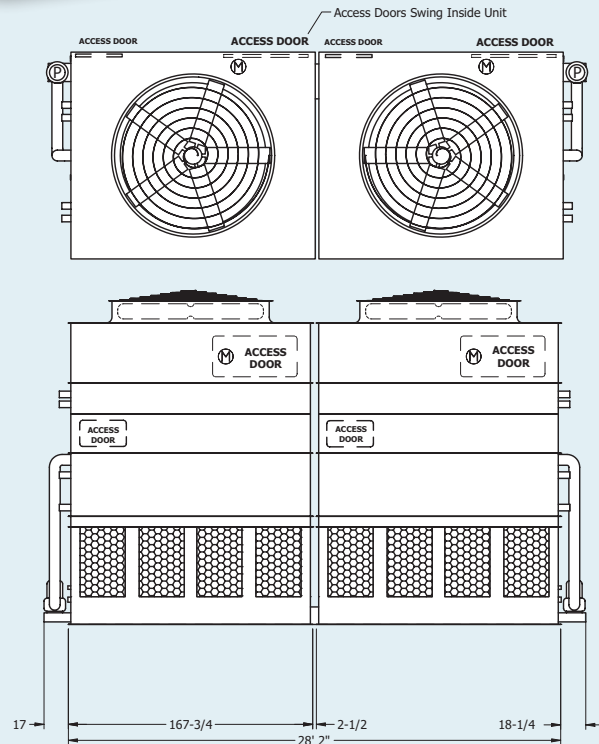
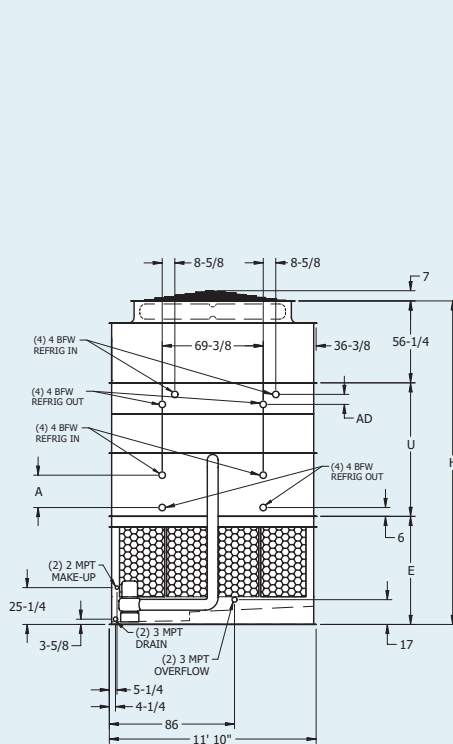

Table 17 Engineering Data

Model No.	R-717 Tons*		Fans		Weights†			Coil Volume (ft.)	NH3 Op. Charge (lbs.)	Spray Pump		Remote Sump		Dimensions (ft)			Dimensions (in)		
	Wet Capacity	Dry Capacity @ 50°F DB Switch Point	HP	CFM	Shipping	Heaviest Section†	Operating			HP	GPM	Gallons Req'd**	Conn. Size	Operating Weight (lbs)	Height H	Lower E	Middle U	Wet Coil A	Dry Coil AD
eco-ATC-H 12-2K28-U22	527	405	2 20	163,900	40,400	13,970	54,150	80	536	2 5	1800	1140	2 12"	45,010	18' 9-7/8"	7' 2-1/4"	6' 11-3/8"	13-3/4"	5-1/2"
eco-ATC-H 12-2K28-U34	533	470	2 20	159,100	42,460	15,000	56,230	87	563	2 5	1800	1140	2 12"	47,090	18' 9-7/8"	7' 2-1/4"	6' 11-3/8"	13-3/4"	6-7/8"
eco-ATC-H 12-2L28-U22	554	424	2 25	174,200	40,460	13,970	54,210	80	536	2 5	1800	1140	2 12"	45,070	18' 9-7/8"	7' 2-1/4"	6' 11-3/8"	13-3/4"	5-1/2"
eco-ATC-H 12-2L28-U34	559	493	2 25	168,800	42,520	15,000	56,290	87	563	2 5	1800	1140	2 12"	47,150	18' 9-7/8"	7' 2-1/4"	6' 11-3/8"	13-3/4"	6-7/8"
eco-ATC-H 12-2M28-U22	576	437	2 30	181,900	40,560	13,970	54,310	80	536	2 5	1800	1140	2 12"	45,170	18' 9-7/8"	7' 2-1/4"	6' 11-3/8"	13-3/4"	5-1/2"
eco-ATC-H 12-2M28-U34	581	509	2 30	175,900	42,620	15,000	56,390	87	563	2 5	1800	1140	2 12"	47,250	18' 9-7/8"	7' 2-1/4"	6' 11-3/8"	13-3/4"	6-7/8"
eco-ATC-H 12-2N28-U22	612	459	2 40	194,400	40,880	13,970	54,630	80	536	2 5	1800	1140	2 12"	45,490	18' 9-7/8"	7' 2-1/4"	6' 11-3/8"	13-3/4"	5-1/2"
eco-ATC-H 12-2N28-U34	617	536	2 40	187,700	42,940	15,000	56,710	87	563	2 5	1800	1140	2 12"	47,570	18' 9-7/8"	7' 2-1/4"	6' 11-3/8"	13-3/4"	6-7/8"
eco-ATC-H 12-3K28-U22	620	430	2 20	163,000	48,020	17,780	61,990	111	760	2 5	1800	1140	2 12"	52,850	19' 6-3/8"	7' 2-1/4"	7' 7-7/8"	22-1/4"	5-1/2"
eco-ATC-H 12-3K28-U34	623	483	2 20	158,900	50,080	18,810	64,070	118	787	2 5	1800	1140	2 12"	54,930	19' 6-3/8"	7' 2-1/4"	7' 7-7/8"	22-1/4"	6-7/8"
eco-ATC-H 12-3L28-U22	652	450	2 25	173,600	48,080	17,780	62,050	111	760	2 5	1800	1140	2 12"	52,910	19' 6-3/8"	7' 2-1/4"	7' 7-7/8"	22-1/4"	5-1/2"
eco-ATC-H 12-3L28-U34	655	507	2 25	168,900	50,140	18,810	64,130	118	787	2 5	1800	1140	2 12"	54,990	19' 6-3/8"	7' 2-1/4"	7' 7-7/8"	22-1/4"	6-7/8"
eco-ATC-H 12-3M28-U22	678	465	2 30	181,400	48,180	17,780	62,150	111	760	2 5	1800	1140	2 12"	53,010	19' 6-3/8"	7' 2-1/4"	7' 7-7/8"	22-1/4"	5-1/2"
eco-ATC-H 12-3M28-U34	681	525	2 30	176,300	50,240	18,810	64,230	118	787	2 5	1800	1140	2 12"	55,090	19' 6-3/8"	7' 2-1/4"	7' 7-7/8"	22-1/4"	6-7/8"
eco-ATC-H 12-3N28-U22	723	489	2 40	194,300	48,500	17,780	62,470	111	760	2 5	1800	1140	2 12"	53,330	19' 6-3/8"	7' 2-1/4"	7' 7-7/8"	22-1/4"	5-1/2"
eco-ATC-H 12-3N28-U34	725	554	2 40	188,400	50,560	18,810	64,550	118	787	2 5	1800	1140	2 12"	55,410	19' 6-3/8"	7' 2-1/4"	7' 7-7/8"	22-1/4"	6-7/8"
eco-ATC-H 12-4K28-U22	687	446	2 20	160,900	55,460	21,500	69,650	141	984	2 5	1800	1140	2 12"	60,510	20' 2-7/8"	7' 2-1/4"	8' 4-3/8"	30-3/4"	5-1/2"
eco-ATC-H 12-4K28-U34	689	489	2 20	157,400	57,520	22,530	71,730	148	1,010	2 5	1800	1140	2 12"	62,590	20' 2-7/8"	7' 2-1/4"	8' 4-3/8"	30-3/4"	6-7/8"
eco-ATC-H 12-4L28-U22	723	468	2 25	171,500	55,520	21,500	69,710	141	984	2 5	1800	1140	2 12"	60,570	20' 2-7/8"	7' 2-1/4"	8' 4-3/8"	30-3/4"	5-1/2"
eco-ATC-H 12-4L28-U34	725	515	2 25	167,500	57,580	22,530	71,790	148	1,010	2 5	1800	1140	2 12"	62,650	20' 2-7/8"	7' 2-1/4"	8' 4-3/8"	30-3/4"	6-7/8"
eco-ATC-H 12-4M28-U22	754	484	2 30	179,400	55,620	21,500	69,810	141	984	2 5	1800	1140	2 12"	60,670	20' 2-7/8"	7' 2-1/4"	8' 4-3/8"	30-3/4"	5-1/2"
eco-ATC-H 12-4M28-U34	755	534	2 30	175,000	57,680	22,530	71,890	148	1,010	2 5	1800	1140	2 12"	62,750	20' 2-7/8"	7' 2-1/4"	8' 4-3/8"	30-3/4"	6-7/8"
eco-ATC-H 12-4N28-U22	804	510	2 40	192,500	55,940	21,500	70,130	141	984	2 5	1800	1140	2 12"	60,990	20' 2-7/8"	7' 2-1/4"	8' 4-3/8"	30-3/4"	5-1/2"
eco-ATC-H 12-4N28-U34	804	565	2 40	187,300	58,000	22,530	72,210	148	1,010	2 5	1800	1140	2 12"	63,070	20' 2-7/8"	7' 2-1/4"	8' 4-3/8"	30-3/4"	6-7/8"

* Tons at standard conditions: 96.3°F condensing, 20°F suction and 78°F W.B.

** Gallons shown is water in suspension in unit and piping. Allow for additional water in bottom of remote sump to cover pump suction and strainer during operation. (12" would normally be sufficient.)

† Heaviest section is the coil section.

Dimensions are subject to change. Do not use for pre-fabrication. Quantity of coil connections subject to change based on refrigerant and design conditions.

NOTE: Interconnecting piping between ARID *fin Pak*™ Dry Coil outlets and Ellipti-*fin*® Coil inlets are field installed and tested (by others).

Engineering Dimensions & Data

eco-ATC-H 12-2K36-U22 to eco-ATC-H 12-4O36-U34

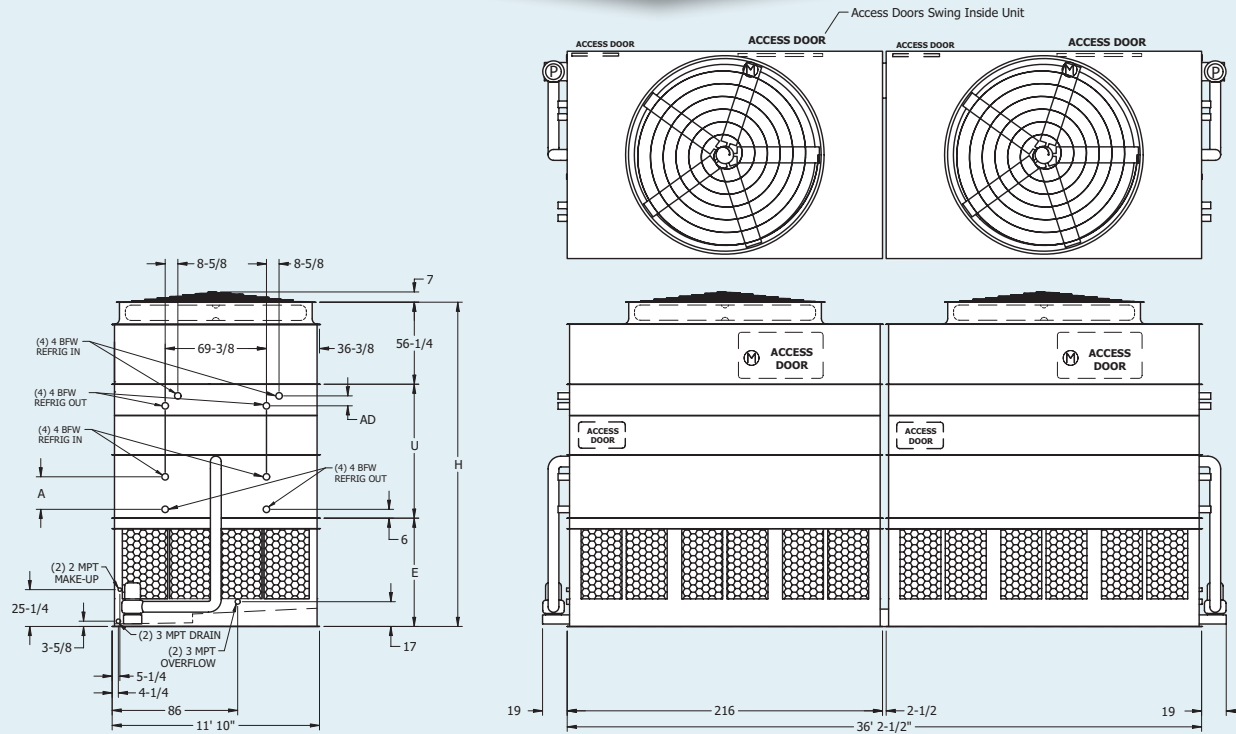

Table 18 Engineering Data

Model No.	R-717 Tons ^s		Fans		Weights [†]			Coil Volume (ft ³)	NH ₃ Op. Charge (lbs.)	Spray Pump		Remote Sump		Dimensions (ft)			Dimensions (in)		
	Wet Capacity	Dry Capacity @ 50°F DB Switch Point	HP	CFM	Shipping	Heaviest Section [†]	Operating			HP	GPM	Gallons Req'd ⁶⁶	Conn. Size	Operating Weight (lbs)	Height H	Lower E	Middle U	Wet Coil A	Dry Coil AD
eco-ATC-H 12-2K36-U22	646	509	2 20	202,700	50,690	17,750	68,070	102	681	2 7.5	2400	1440	2 12"	56,330	18' 9-7/8"	7' 2-1/4"	6' 11-3/8"	13-3/4"	5-1/2"
eco-ATC-H 12-2K36-U34	655	590	2 20	197,200	53,340	19,070	70,760	111	715	2 7.5	2400	1440	2 12"	59,020	18' 9-7/8"	7' 2-1/4"	6' 11-3/8"	13-3/4"	6-7/8"
eco-ATC-H 12-2L36-U22	679	533	2 25	216,100	50,750	17,750	68,130	102	681	2 7.5	2400	1440	2 12"	56,390	18' 9-7/8"	7' 2-1/4"	6' 11-3/8"	13-3/4"	5-1/2"
eco-ATC-H 12-2L36-U34	687	620	2 25	209,800	53,400	19,070	70,820	111	715	2 7.5	2400	1440	2 12"	59,080	18' 9-7/8"	7' 2-1/4"	6' 11-3/8"	13-3/4"	6-7/8"
eco-ATC-H 12-2M36-U22	707	554	2 30	227,600	50,850	17,750	68,230	102	681	2 7.5	2400	1440	2 12"	56,490	18' 9-7/8"	7' 2-1/4"	6' 11-3/8"	13-3/4"	5-1/2"
eco-ATC-H 12-2M36-U34	715	645	2 30	220,500	53,500	19,070	70,920	111	715	2 7.5	2400	1440	2 12"	59,180	18' 9-7/8"	7' 2-1/4"	6' 11-3/8"	13-3/4"	6-7/8"
eco-ATC-H 12-2N36-U22	752	582	2 40	243,800	51,170	17,750	68,550	102	681	2 7.5	2400	1440	2 12"	56,810	18' 9-7/8"	7' 2-1/4"	6' 11-3/8"	13-3/4"	5-1/2"
eco-ATC-H 12-2N36-U34	759	680	2 40	235,800	53,820	19,070	71,240	111	715	2 7.5	2400	1440	2 12"	59,500	18' 9-7/8"	7' 2-1/4"	6' 11-3/8"	13-3/4"	6-7/8"
eco-ATC-H 12-3K36-U22	757	538	2 20	201,200	60,210	22,510	77,890	141	970	2 7.5	2400	1440	2 12"	66,150	19' 6-3/8"	7' 2-1/4"	7' 7-7/8"	22-1/4"	5-1/2"
eco-ATC-H 12-3K36-U34	764	604	2 20	196,600	62,860	23,830	80,580	150	1,004	2 7.5	2400	1440	2 12"	68,840	19' 6-3/8"	7' 2-1/4"	7' 7-7/8"	22-1/4"	6-7/8"
eco-ATC-H 12-3L36-U22	797	565	2 25	214,900	60,270	22,510	77,950	141	970	2 7.5	2400	1440	2 12"	66,210	19' 6-3/8"	7' 2-1/4"	7' 7-7/8"	22-1/4"	5-1/2"
eco-ATC-H 12-3L36-U34	803	636	2 25	209,500	62,920	23,830	80,640	150	1,004	2 7.5	2400	1440	2 12"	68,900	19' 6-3/8"	7' 2-1/4"	7' 7-7/8"	22-1/4"	6-7/8"
eco-ATC-H 12-3M36-U22	831	588	2 30	226,600	60,370	22,510	78,050	141	970	2 7.5	2400	1440	2 12"	66,310	19' 6-3/8"	7' 2-1/4"	7' 7-7/8"	22-1/4"	5-1/2"
eco-ATC-H 12-3M36-U34	837	663	2 30	220,600	63,020	23,830	80,740	150	1,004	2 7.5	2400	1440	2 12"	69,000	19' 6-3/8"	7' 2-1/4"	7' 7-7/8"	22-1/4"	6-7/8"
eco-ATC-H 12-3N36-U22	886	619	2 40	243,200	60,690	22,510	78,370	141	970	2 7.5	2400	1440	2 12"	66,630	19' 6-3/8"	7' 2-1/4"	7' 7-7/8"	22-1/4"	5-1/2"
eco-ATC-H 12-3N36-U34	890	701	2 40	236,300	63,340	23,830	81,060	150	1,004	2 7.5	2400	1440	2 12"	69,320	19' 6-3/8"	7' 2-1/4"	7' 7-7/8"	22-1/4"	6-7/8"
eco-ATC-H 12-3O36-U22	930	643	2 50	256,600	60,710	22,510	78,390	141	970	2 7.5	2400	1440	2 12"	66,650	19' 6-3/8"	7' 2-1/4"	7' 7-7/8"	22-1/4"	5-1/2"
eco-ATC-H 12-3O36-U34	934	731	2 50	248,800	63,360	23,830	81,080	150	1,004	2 7.5	2400	1440	2 12"	69,340	19' 6-3/8"	7' 2-1/4"	7' 7-7/8"	22-1/4"	6-7/8"
eco-ATC-H 12-4K36-U22	838	557	2 20	198,200	69,710	27,260	87,670	181	1,259	2 7.5	2400	1440	2 12"	75,930	20' 2-7/8"	7' 2-1/4"	8' 4-3/8"	30-3/4"	5-1/2"
eco-ATC-H 12-4K36-U34	843	609	2 20	194,300	72,360	28,580	90,360	190	1,293	2 7.5	2400	1440	2 12"	78,620	20' 2-7/8"	7' 2-1/4"	8' 4-3/8"	30-3/4"	6-7/8"
eco-ATC-H 12-4L36-U22	883	586	2 25	211,900	69,770	27,260	87,730	181	1,259	2 7.5	2400	1440	2 12"	75,990	20' 2-7/8"	7' 2-1/4"	8' 4-3/8"	30-3/4"	5-1/2"
eco-ATC-H 12-4L36-U34	888	644	2 25	207,400	72,420	28,580	90,420	190	1,293	2 7.5	2400	1440	2 12"	78,680	20' 2-7/8"	7' 2-1/4"	8' 4-3/8"	30-3/4"	6-7/8"
eco-ATC-H 12-4M36-U22	922	611	2 30	223,800	69,870	27,260	87,830	181	1,259	2 7.5	2400	1440	2 12"	76,090	20' 2-7/8"	7' 2-1/4"	8' 4-3/8"	30-3/4"	5-1/2"
eco-ATC-H 12-4M36-U34	926	673	2 30	218,700	72,520	28,580	90,520	190	1,293	2 7.5	2400	1440	2 12"	78,780	20' 2-7/8"	7' 2-1/4"	8' 4-3/8"	30-3/4"	6-7/8"
eco-ATC-H 12-4N36-U22	984	645	2 40	240,500	70,190	27,260	88,150	181	1,259	2 7.5	2400	1440	2 12"	76,410	20' 2-7/8"	7' 2-1/4"	8' 4-3/8"	30-3/4"	5-1/2"
eco-ATC-H 12-4N36-U34	987	713	2 40	234,600	72,840	28,580	90,840	190	1,293	2 7.5	2400	1440	2 12"	79,100	20' 2-7/8"	7' 2-1/4"	8' 4-3/8"	30-3/4"	6-7/8"
eco-ATC-H 12-4O36-U22	1,034	671	2 50	254,100	70,210	27,260	88,170	181	1,259	2 7.5	2400	1440	2 12"	76,430	20' 2-7/8"	7' 2-1/4"	8' 4-3/8"	30-3/4"	5-1/2"
eco-ATC-H 12-4O36-U34	1,036	745	2 50	247,300	72,860	28,580	90,860	190	1,293	2 7.5	2400	1440	2 12"	79,120	20' 2-7/8"	7' 2-1/4"	8' 4-3/8"	30-3/4"	6-7/8"

* Tons at standard conditions: 96.3°F condensing, 20°F suction and 78°F W.B.

** Gallons shown is water in suspension in unit and piping. Allow for additional water in bottom of remote sump to cover pump suction and strainer during operation. (12" would normally be sufficient.)

† Heaviest section is the coil section.

Dimensions are subject to change. Do not use for pre-fabrication. Quantity of coil connections subject to change based on refrigerant and design conditions.

NOTE: Interconnecting piping between ARID *fin Pak*™ Dry Coil outlets and Ellipti-*fin*® Coil inlets are field installed and tested (by others).

Engineering Dimensions & Data

eco-ATC-H 12-2L40-U22 to eco-ATC-H 12-4P40-U34

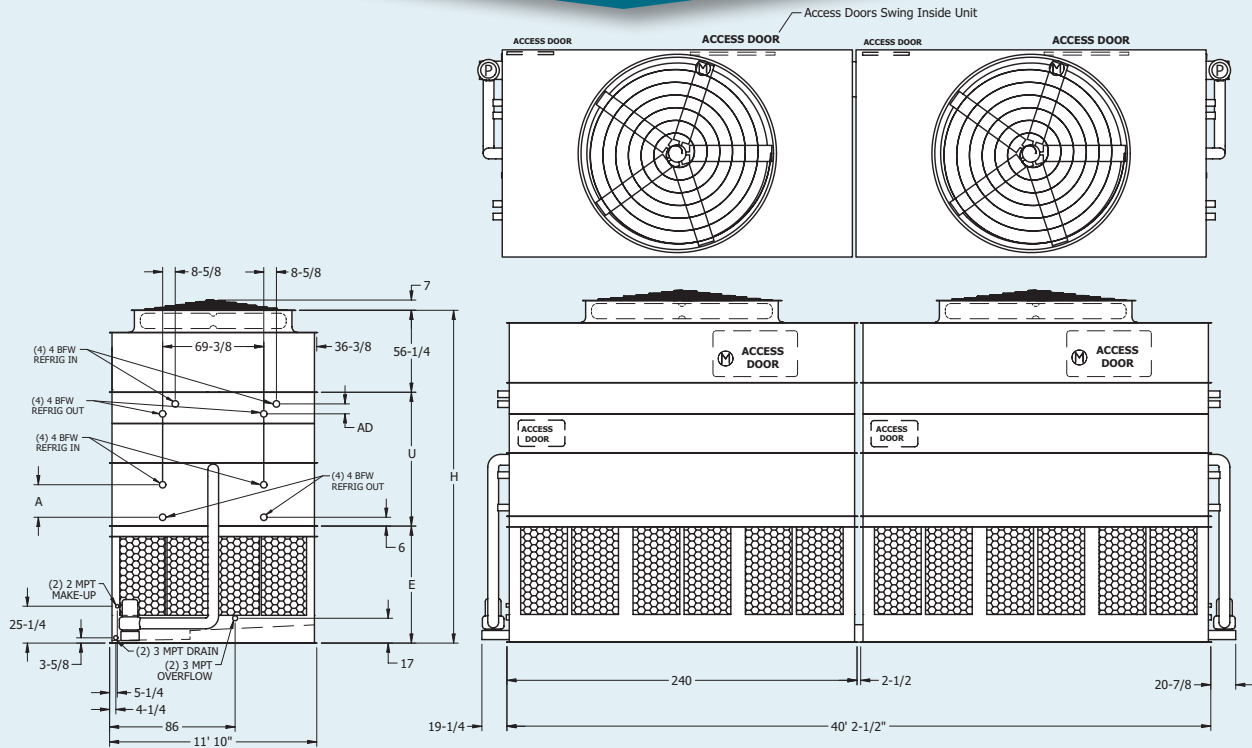

Table 19 Engineering Data

Model No.	R-717 Tons*		Fans		Weights†			Coil Volume (ft.)	NH3 Op. Charge (lbs.)	Spray Pump		Remote Sump			Dimensions (ft)			Dimensions (in)	
	Wet Capacity	Dry Capacity @ 50°F DB Switch Point	HP	CFM	Shipping	Heaviest Section†	Operating			HP	GPM	Gallons Req'd**	Conn. Size	Operating Weight (lbs)	Height H	Lower E	Middle U	Wet Coil A	Dry Coil AD
eco-ATC-H 12-2L40-U22	738	573	2 25	233,400	55,580	19,390	75,210	113	755	2 10	2800	1600	2 14"	61,810	18' 9-7/8"	7' 2-1/4"	6' 11-3/8"	13-3/4"	5-1/2"
eco-ATC-H 12-2L40-U34	748	671	2 25	226,900	58,530	20,870	78,210	123	792	2 10	2800	1600	2 14"	64,810	18' 9-7/8"	7' 2-1/4"	6' 11-3/8"	13-3/4"	6-7/8"
eco-ATC-H 12-2M40-U22	769	595	2 30	245,900	55,680	19,390	75,310	113	755	2 10	2800	1600	2 14"	61,910	18' 9-7/8"	7' 2-1/4"	6' 11-3/8"	13-3/4"	5-1/2"
eco-ATC-H 12-2M40-U34	778	698	2 30	238,600	58,630	20,870	78,310	123	792	2 10	2800	1600	2 14"	64,910	18' 9-7/8"	7' 2-1/4"	6' 11-3/8"	13-3/4"	6-7/8"
eco-ATC-H 12-2N40-U22	818	629	2 40	264,800	56,000	19,390	75,630	113	755	2 10	2800	1600	2 14"	62,230	18' 9-7/8"	7' 2-1/4"	6' 11-3/8"	13-3/4"	5-1/2"
eco-ATC-H 12-2N40-U34	827	739	2 40	256,400	58,950	20,870	78,630	123	792	2 10	2800	1600	2 14"	65,230	18' 9-7/8"	7' 2-1/4"	6' 11-3/8"	13-3/4"	6-7/8"
eco-ATC-H 12-2O40-U22	858	653	2 50	279,000	56,020	19,390	75,650	113	755	2 10	2800	1600	2 14"	62,250	18' 9-7/8"	7' 2-1/4"	6' 11-3/8"	13-3/4"	5-1/2"
eco-ATC-H 12-2O40-U34	867	770	2 50	269,700	58,970	20,870	78,650	123	792	2 10	2800	1600	2 14"	65,250	18' 9-7/8"	7' 2-1/4"	6' 11-3/8"	13-3/4"	6-7/8"
eco-ATC-H 12-3L40-U22	866	605	2 25	231,800	66,320	24,760	86,270	157	1,077	2 10	2800	1600	2 14"	72,870	19' 6-3/8"	7' 2-1/4"	7' 7-7/8"	22-1/4"	5-1/2"
eco-ATC-H 12-3L40-U34	873	687	2 25	226,400	69,270	26,240	89,270	167	1,113	2 10	2800	1600	2 14"	75,870	19' 6-3/8"	7' 2-1/4"	7' 7-7/8"	22-1/4"	6-7/8"
eco-ATC-H 12-3M40-U22	903	629	2 30	244,600	66,420	24,760	86,370	157	1,077	2 10	2800	1600	2 14"	72,970	19' 6-3/8"	7' 2-1/4"	7' 7-7/8"	22-1/4"	5-1/2"
eco-ATC-H 12-3M40-U34	910	717	2 30	238,400	69,370	26,240	89,370	167	1,113	2 10	2800	1600	2 14"	75,970	19' 6-3/8"	7' 2-1/4"	7' 7-7/8"	22-1/4"	6-7/8"
eco-ATC-H 12-3N40-U22	963	665	2 40	263,900	66,740	24,760	86,690	157	1,077	2 10	2800	1600	2 14"	73,290	19' 6-3/8"	7' 2-1/4"	7' 7-7/8"	22-1/4"	5-1/2"
eco-ATC-H 12-3N40-U34	969	760	2 40	256,700	69,690	26,240	89,690	167	1,113	2 10	2800	1600	2 14"	76,290	19' 6-3/8"	7' 2-1/4"	7' 7-7/8"	22-1/4"	6-7/8"
eco-ATC-H 12-3O40-U22	1,011	692	2 50	278,500	66,760	24,760	86,710	157	1,077	2 10	2800	1600	2 14"	73,310	19' 6-3/8"	7' 2-1/4"	7' 7-7/8"	22-1/4"	5-1/2"
eco-ATC-H 12-3O40-U34	1,017	793	2 50	270,400	69,710	26,240	89,710	167	1,113	2 10	2800	1600	2 14"	76,310	19' 6-3/8"	7' 2-1/4"	7' 7-7/8"	22-1/4"	6-7/8"
eco-ATC-H 12-3P40-U22	1,053	714	2 60	290,900	67,160	24,760	87,110	157	1,077	2 10	2800	1600	2 14"	73,710	19' 6-3/8"	7' 2-1/4"	7' 7-7/8"	22-1/4"	5-1/2"
eco-ATC-H 12-3P40-U34	1,057	820	2 60	282,100	70,110	26,240	90,110	167	1,113	2 10	2800	1600	2 14"	76,710	19' 6-3/8"	7' 2-1/4"	7' 7-7/8"	22-1/4"	6-7/8"
eco-ATC-H 12-4L40-U22	959	626	2 25	228,500	76,800	30,000	97,070	201	1,398	2 10	2800	1600	2 14"	83,670	20' 2-7/8"	7' 2-1/4"	8' 4-3/8"	30-3/4"	5-1/2"
eco-ATC-H 12-4L40-U34	964	694	2 25	223,900	79,750	31,480	100,070	211	1,435	2 10	2800	1600	2 14"	86,670	20' 2-7/8"	7' 2-1/4"	8' 4-3/8"	30-3/4"	6-7/8"
eco-ATC-H 12-4M40-U22	1,001	652	2 30	241,300	76,900	30,000	97,170	201	1,398	2 10	2800	1600	2 14"	83,770	20' 2-7/8"	7' 2-1/4"	8' 4-3/8"	30-3/4"	5-1/2"
eco-ATC-H 12-4M40-U34	1,006	725	2 30	236,100	79,850	31,480	100,170	211	1,435	2 10	2800	1600	2 14"	86,770	20' 2-7/8"	7' 2-1/4"	8' 4-3/8"	30-3/4"	6-7/8"
eco-ATC-H 12-4N40-U22	1,069	691	2 40	260,800	77,220	30,000	97,490	201	1,398	2 10	2800	1600	2 14"	84,090	20' 2-7/8"	7' 2-1/4"	8' 4-3/8"	30-3/4"	5-1/2"
eco-ATC-H 12-4N40-U34	1,073	772	2 40	254,600	80,170	31,480	100,490	211	1,435	2 10	2800	1600	2 14"	87,090	20' 2-7/8"	7' 2-1/4"	8' 4-3/8"	30-3/4"	6-7/8"
eco-ATC-H 12-4O40-U22	1,124	720	2 50	275,600	77,240	30,000	97,510	201	1,398	2 10	2800	1600	2 14"	84,110	20' 2-7/8"	7' 2-1/4"	8' 4-3/8"	30-3/4"	5-1/2"
eco-ATC-H 12-4O40-U34	1,127	806	2 50	268,600	80,190	31,480	100,510	211	1,435	2 10	2800	1600	2 14"	87,110	20' 2-7/8"	7' 2-1/4"	8' 4-3/8"	30-3/4"	6-7/8"
eco-ATC-H 12-4P40-U22	1,171	744	2 60	288,100	77,640	30,000	97,910	201	1,398	2 10	2800	1600	2 14"	84,510	20' 2-7/8"	7' 2-1/4"	8' 4-3/8"	30-3/4"	5-1/2"
eco-ATC-H 12-4P40-U34	1,173	835	2 60	280,400	80,590	31,480	100,910	211	1,435	2 10	2800	1600	2 14"	87,510	20' 2-7/8"	7' 2-1/4"	8' 4-3/8"	30-3/4"	6-7/8"

* Tons at standard conditions: 96.3°F condensing, 20°F suction and 78°F W.B.

** Gallons shown is water in suspension in unit and piping. Allow for additional water in bottom of remote sump to cover pump suction and strainer during operation. (12" would normally be sufficient.)

† Heaviest section is the coil section.

Dimensions are subject to change. Do not use for pre-fabrication. Quantity of coil connections subject to change based on refrigerant and design conditions.

NOTE: Interconnecting piping between ARID fin Pak™ Dry Coil outlets and Ellipti-fin® Coil inlets are field installed and tested (by others).

Engineering Dimensions & Data

eco-ATC-H 24-2J12-U22 to eco-ATC-H 24-4N12-U34

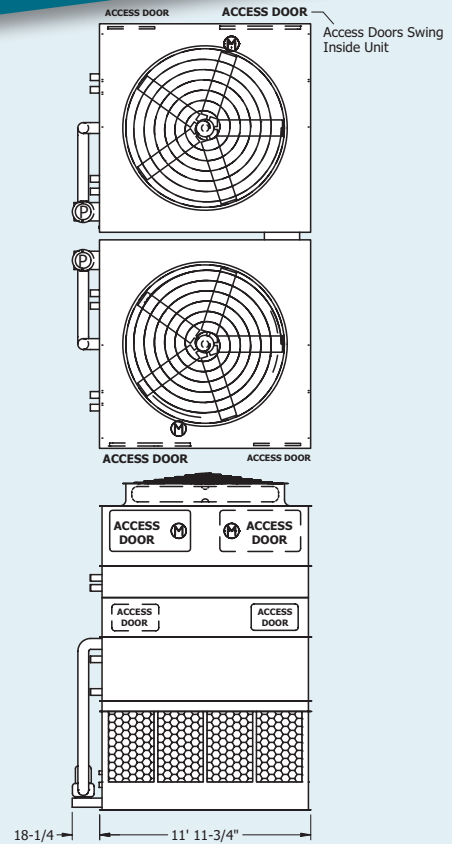
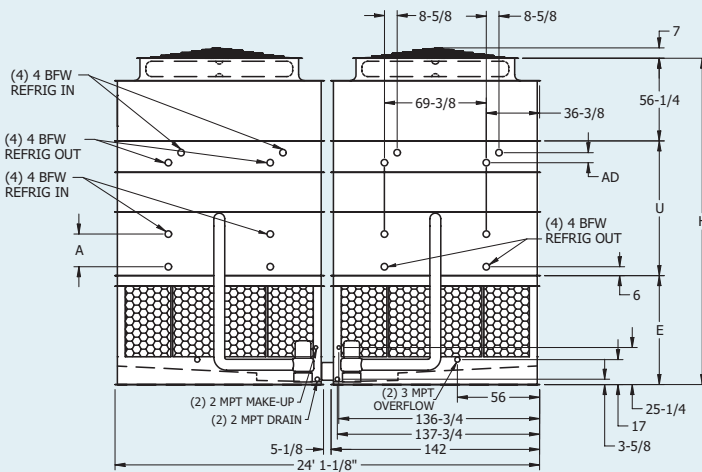

Table 20 Engineering Data

Model No.	R-717 Tons [*]		Fans		Weights [†]			Coil Volume (ft ³)	NH ₃ Op. Charge (lbs.)	Spray Pump		Remote Sump		Dimensions (ft)			Dimensions (in)		
	Wet Capacity	Dry Capacity @ 50°F DB Switch Point	HP	CFM	Shipping	Heaviest Section [†]	Operating			HP	GPM	Gallons Req'd ^{**}	Conn. Size	Operating Weight (lbs)	Height H	Lower E	Middle U	Wet Coil A	Dry Coil AD
eco-ATC-H 24-2J12-U22	438	337	2 15	135,100	35,770	12,340	47,420	69	464	2 5	1600	980	2 12"	39,520	17' 9-7/8"	6' 2-1/4"	6' 11-3/8"	13-3/4"	5-1/2"
eco-ATC-H 24-2J12-U34	443	390	2 15	131,200	37,520	13,210	49,180	75	486	2 5	1600	980	2 12"	41,280	17' 9-7/8"	6' 2-1/4"	6' 11-3/8"	13-3/4"	6-7/8"
eco-ATC-H 24-2K12-U22	467	358	2 20	146,600	35,890	12,340	47,540	69	464	2 5	1600	980	2 12"	39,640	17' 9-7/8"	6' 2-1/4"	6' 11-3/8"	13-3/4"	5-1/2"
eco-ATC-H 24-2K12-U34	472	416	2 20	142,000	37,640	13,210	49,300	75	486	2 5	1600	980	2 12"	41,400	17' 9-7/8"	6' 2-1/4"	6' 11-3/8"	13-3/4"	6-7/8"
eco-ATC-H 24-2L12-U22	490	372	2 25	154,600	35,950	12,340	47,600	69	464	2 5	1600	980	2 12"	39,700	17' 9-7/8"	6' 2-1/4"	6' 11-3/8"	13-3/4"	5-1/2"
eco-ATC-H 24-2L12-U34	494	433	2 25	149,600	37,700	13,210	49,360	75	486	2 5	1600	980	2 12"	41,460	17' 9-7/8"	6' 2-1/4"	6' 11-3/8"	13-3/4"	6-7/8"
eco-ATC-H 24-2M12-U22	510	384	2 30	161,400	36,050	12,340	47,700	69	464	2 5	1600	980	2 12"	39,800	17' 9-7/8"	6' 2-1/4"	6' 11-3/8"	13-3/4"	5-1/2"
eco-ATC-H 24-2M12-U34	513	448	2 30	155,900	37,800	13,210	49,460	75	486	2 5	1600	980	2 12"	41,560	17' 9-7/8"	6' 2-1/4"	6' 11-3/8"	13-3/4"	6-7/8"
eco-ATC-H 24-3J12-U22	515	357	2 15	134,200	42,150	15,530	54,000	95	655	2 5	1600	980	2 12"	46,100	18' 6-3/8"	6' 2-1/4"	7' 7-7/8"	22-1/4"	5-1/2"
eco-ATC-H 24-3J12-U34	518	400	2 15	131,000	43,900	16,400	55,760	101	677	2 5	1600	980	2 12"	47,860	18' 6-3/8"	6' 2-1/4"	7' 7-7/8"	22-1/4"	6-7/8"
eco-ATC-H 24-3K12-U22	549	380	2 20	146,000	42,270	15,530	54,120	95	655	2 5	1600	980	2 12"	46,220	18' 6-3/8"	6' 2-1/4"	7' 7-7/8"	22-1/4"	5-1/2"
eco-ATC-H 24-3K12-U34	552	428	2 20	142,100	44,020	16,400	55,880	101	677	2 5	1600	980	2 12"	47,980	18' 6-3/8"	6' 2-1/4"	7' 7-7/8"	22-1/4"	6-7/8"
eco-ATC-H 24-3L12-U22	577	396	2 25	154,300	42,330	15,530	54,180	95	655	2 5	1600	980	2 12"	46,280	18' 6-3/8"	6' 2-1/4"	7' 7-7/8"	22-1/4"	5-1/2"
eco-ATC-H 24-3L12-U34	580	447	2 25	149,900	44,080	16,400	55,940	101	677	2 5	1600	980	2 12"	48,040	18' 6-3/8"	6' 2-1/4"	7' 7-7/8"	22-1/4"	6-7/8"
eco-ATC-H 24-3M12-U22	601	408	2 30	161,200	42,430	15,530	54,280	95	655	2 5	1600	980	2 12"	46,380	18' 6-3/8"	6' 2-1/4"	7' 7-7/8"	22-1/4"	5-1/2"
eco-ATC-H 24-3M12-U34	603	462	2 30	156,400	44,180	16,400	56,040	101	677	2 5	1600	980	2 12"	48,140	18' 6-3/8"	6' 2-1/4"	7' 7-7/8"	22-1/4"	6-7/8"
eco-ATC-H 24-3N12-U22	640	429	2 40	172,500	42,750	15,530	54,600	95	655	2 5	1600	980	2 12"	46,700	18' 6-3/8"	6' 2-1/4"	7' 7-7/8"	22-1/4"	5-1/2"
eco-ATC-H 24-3N12-U34	641	487	2 40	167,100	44,500	16,400	56,360	101	677	2 5	1600	980	2 12"	48,460	18' 6-3/8"	6' 2-1/4"	7' 7-7/8"	22-1/4"	6-7/8"
eco-ATC-H 24-4K12-U22	610	395	2 20	144,200	48,650	18,720	60,700	121	846	2 5	1600	980	2 12"	52,800	19' 2-7/8"	6' 2-1/4"	8' 4-3/8"	30-3/4"	5-1/2"
eco-ATC-H 24-4K12-U34	611	434	2 20	140,900	50,400	19,590	62,460	127	868	2 5	1600	980	2 12"	54,560	19' 2-7/8"	6' 2-1/4"	8' 4-3/8"	30-3/4"	6-7/8"
eco-ATC-H 24-4L12-U22	641	412	2 25	152,600	48,710	18,720	60,760	121	846	2 5	1600	980	2 12"	52,860	19' 2-7/8"	6' 2-1/4"	8' 4-3/8"	30-3/4"	5-1/2"
eco-ATC-H 24-4L12-U34	642	454	2 25	148,800	50,460	19,590	62,520	127	868	2 5	1600	980	2 12"	54,620	19' 2-7/8"	6' 2-1/4"	8' 4-3/8"	30-3/4"	6-7/8"
eco-ATC-H 24-4M12-U22	668	426	2 30	159,500	48,810	18,720	60,860	121	846	2 5	1600	980	2 12"	52,960	19' 2-7/8"	6' 2-1/4"	8' 4-3/8"	30-3/4"	5-1/2"
eco-ATC-H 24-4M12-U34	669	471	2 30	155,400	50,560	19,590	62,620	127	868	2 5	1600	980	2 12"	54,720	19' 2-7/8"	6' 2-1/4"	8' 4-3/8"	30-3/4"	6-7/8"
eco-ATC-H 24-4N12-U22	713	448	2 40	171,100	49,130	18,720	61,180	121	846	2 5	1600	980	2 12"	53,280	19' 2-7/8"	6' 2-1/4"	8' 4-3/8"	30-3/4"	5-1/2"
eco-ATC-H 24-4N12-U34	712	497	2 40	166,300	50,880	19,590	62,940	127	868	2 5	1600	980	2 12"	55,040	19' 2-7/8"	6' 2-1/4"	8' 4-3/8"	30-3/4"	6-7/8"

* Tons at standard conditions: 96.3°F condensing, 20°F suction and 78°F W.B.

** Gallons shown is water in suspension in unit and piping. Allow for additional water in bottom of remote sump to cover pump suction and strainer during operation. (12" would normally be sufficient.)

† Heaviest section is the coil section.

Dimensions are subject to change. Do not use for pre-fabrication. Quantity of coil connections subject to change based on refrigerant and design conditions.

NOTE: Interconnecting piping between ARID *fin Pak*™ Dry Coil outlets and Ellipti-*fin*® Coil inlets are field installed and tested (by others).

Engineering Dimensions & Data

eco-ATC-H 24-2K14-U22 to eco-ATC-H 24-4N14-U34

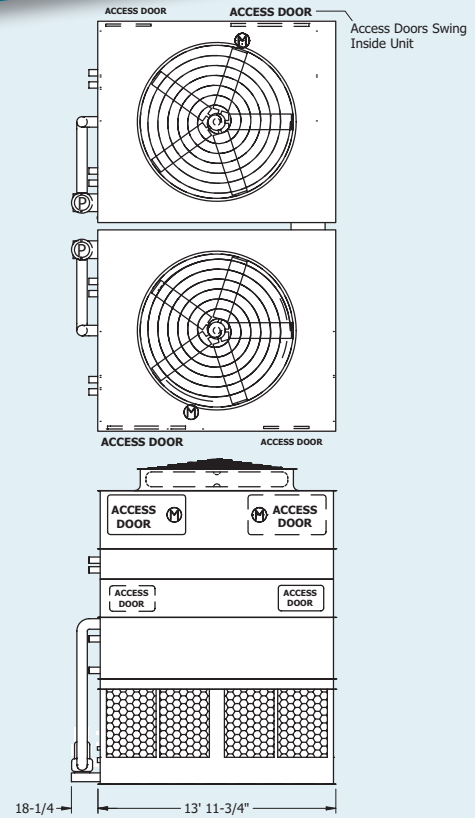
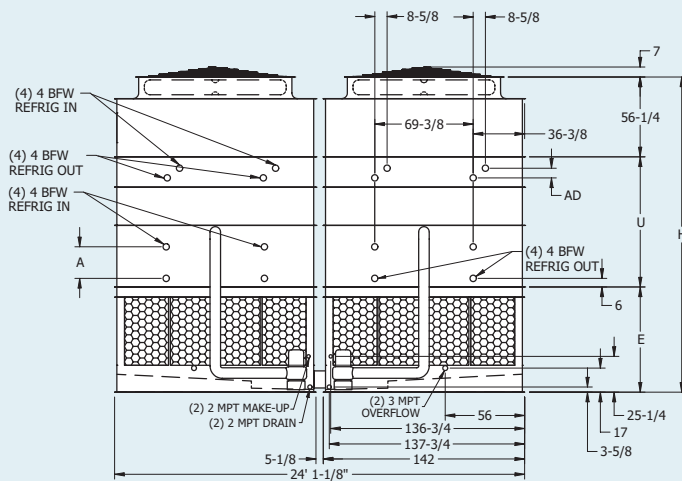

Table 21 Engineering Data

Model No.	R-717 Tons*		Fans		Weights†		Coil Volume (ft.)	NH3 Op. Charge (lbs.)	Spray Pump		Remote Sump		Dimensions (ft)			Dimensions (in)			
	Wet Capacity	Dry Capacity @ 50°F DB Switch Point	HP	CFM	Shipping	Heaviest Section†			Operating	HP	GPM	Gallons Req'd**	Conn. Size	Operating Weight (lbs)	Height H	Lower E	Middle U	Wet Coil A	Dry Coil AD
eco-ATC-H 24-2K14-U22	527	405	2 20	163,900	40,420	13,980	54,170	80	536	2 5	1800	1140	2 12"	45,030	18' 9-7/8"	7' 2-1/4"	6' 11-3/8"	13-3/4"	5-1/2"
eco-ATC-H 24-2K14-U34	533	470	2 20	159,100	42,480	15,010	56,250	87	563	2 5	1800	1140	2 12"	47,110	18' 9-7/8"	7' 2-1/4"	6' 11-3/8"	13-3/4"	6-7/8"
eco-ATC-H 24-2L14-U22	554	424	2 25	174,200	40,480	13,980	54,230	80	536	2 5	1800	1140	2 12"	45,090	18' 9-7/8"	7' 2-1/4"	6' 11-3/8"	13-3/4"	5-1/2"
eco-ATC-H 24-2L14-U34	559	493	2 25	168,800	42,540	15,010	56,310	87	563	2 5	1800	1140	2 12"	47,170	18' 9-7/8"	7' 2-1/4"	6' 11-3/8"	13-3/4"	6-7/8"
eco-ATC-H 24-2M14-U22	576	437	2 30	181,900	40,580	13,980	54,330	80	536	2 5	1800	1140	2 12"	45,190	18' 9-7/8"	7' 2-1/4"	6' 11-3/8"	13-3/4"	5-1/2"
eco-ATC-H 24-2M14-U34	581	509	2 30	175,900	42,640	15,010	56,410	87	563	2 5	1800	1140	2 12"	47,270	18' 9-7/8"	7' 2-1/4"	6' 11-3/8"	13-3/4"	6-7/8"
eco-ATC-H 24-2N14-U22	612	459	2 40	194,400	40,900	13,980	54,650	80	536	2 5	1800	1140	2 12"	45,510	18' 9-7/8"	7' 2-1/4"	6' 11-3/8"	13-3/4"	5-1/2"
eco-ATC-H 24-2N14-U34	617	536	2 40	187,700	42,960	15,010	56,730	87	563	2 5	1800	1140	2 12"	47,590	18' 9-7/8"	7' 2-1/4"	6' 11-3/8"	13-3/4"	6-7/8"
eco-ATC-H 24-3K14-U22	620	430	2 20	163,000	48,020	17,780	61,990	111	760	2 5	1800	1140	2 12"	52,850	19' 6-3/8"	7' 2-1/4"	7' 7-7/8"	22-1/4"	5-1/2"
eco-ATC-H 24-3K14-U34	623	483	2 20	158,900	50,080	18,810	64,070	118	787	2 5	1800	1140	2 12"	54,930	19' 6-3/8"	7' 2-1/4"	7' 7-7/8"	22-1/4"	6-7/8"
eco-ATC-H 24-3L14-U22	652	450	2 25	173,600	48,080	17,780	62,050	111	760	2 5	1800	1140	2 12"	52,910	19' 6-3/8"	7' 2-1/4"	7' 7-7/8"	22-1/4"	5-1/2"
eco-ATC-H 24-3L14-U34	655	507	2 25	168,900	50,140	18,810	64,130	118	787	2 5	1800	1140	2 12"	54,990	19' 6-3/8"	7' 2-1/4"	7' 7-7/8"	22-1/4"	6-7/8"
eco-ATC-H 24-3M14-U22	678	465	2 30	181,400	48,180	17,780	62,150	111	760	2 5	1800	1140	2 12"	53,010	19' 6-3/8"	7' 2-1/4"	7' 7-7/8"	22-1/4"	5-1/2"
eco-ATC-H 24-3M14-U34	681	525	2 30	176,300	50,240	18,810	64,230	118	787	2 5	1800	1140	2 12"	55,090	19' 6-3/8"	7' 2-1/4"	7' 7-7/8"	22-1/4"	6-7/8"
eco-ATC-H 24-3N14-U22	723	489	2 40	194,300	48,500	17,780	62,470	111	760	2 5	1800	1140	2 12"	53,330	19' 6-3/8"	7' 2-1/4"	7' 7-7/8"	22-1/4"	5-1/2"
eco-ATC-H 24-3N14-U34	725	554	2 40	188,400	50,560	18,810	64,550	118	787	2 5	1800	1140	2 12"	55,410	19' 6-3/8"	7' 2-1/4"	7' 7-7/8"	22-1/4"	6-7/8"
eco-ATC-H 24-4K14-U22	687	446	2 20	160,900	55,460	21,500	69,650	141	984	2 5	1800	1140	2 12"	60,510	20' 2-7/8"	7' 2-1/4"	8' 4-3/8"	30-3/4"	5-1/2"
eco-ATC-H 24-4K14-U34	689	489	2 20	157,400	57,520	22,530	71,730	148	1,010	2 5	1800	1140	2 12"	62,590	20' 2-7/8"	7' 2-1/4"	8' 4-3/8"	30-3/4"	6-7/8"
eco-ATC-H 24-4L14-U22	723	468	2 25	171,500	55,520	21,500	69,710	141	984	2 5	1800	1140	2 12"	60,570	20' 2-7/8"	7' 2-1/4"	8' 4-3/8"	30-3/4"	5-1/2"
eco-ATC-H 24-4L14-U34	725	515	2 25	167,500	57,580	22,530	71,790	148	1,010	2 5	1800	1140	2 12"	62,650	20' 2-7/8"	7' 2-1/4"	8' 4-3/8"	30-3/4"	6-7/8"
eco-ATC-H 24-4M14-U22	754	484	2 30	179,400	55,620	21,500	69,810	141	984	2 5	1800	1140	2 12"	60,670	20' 2-7/8"	7' 2-1/4"	8' 4-3/8"	30-3/4"	5-1/2"
eco-ATC-H 24-4M14-U34	755	534	2 30	175,000	57,680	22,530	71,890	148	1,010	2 5	1800	1140	2 12"	62,750	20' 2-7/8"	7' 2-1/4"	8' 4-3/8"	30-3/4"	6-7/8"
eco-ATC-H 24-4N14-U22	804	510	2 40	192,500	55,940	21,500	70,130	141	984	2 5	1800	1140	2 12"	60,990	20' 2-7/8"	7' 2-1/4"	8' 4-3/8"	30-3/4"	5-1/2"
eco-ATC-H 24-4N14-U34	804	565	2 40	187,300	58,000	22,530	72,210	148	1,010	2 5	1800	1140	2 12"	63,070	20' 2-7/8"	7' 2-1/4"	8' 4-3/8"	30-3/4"	6-7/8"

* Tons at standard conditions: 96.3°F condensing, 20°F suction and 78°F W.B.

** Gallons shown is water in suspension in unit and piping. Allow for additional water in bottom of remote sump to cover pump suction and strainer during operation. (12" would normally be sufficient.)

† Heaviest section is the coil section.

Dimensions are subject to change. Do not use for pre-fabrication. Quantity of coil connections subject to change based on refrigerant and design conditions.

NOTE: Interconnecting piping between ARID fin Pak™ Dry Coil outlets and Ellipti-fin® Coil inlets are field installed and tested (by others).

Engineering Dimensions & Data

eco-ATC-H 24-2K18-U22 to eco-ATC-H 24-4O18-U34

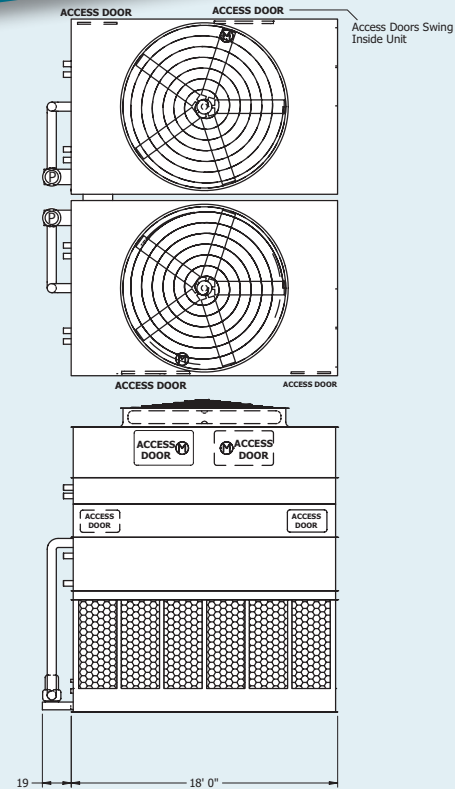
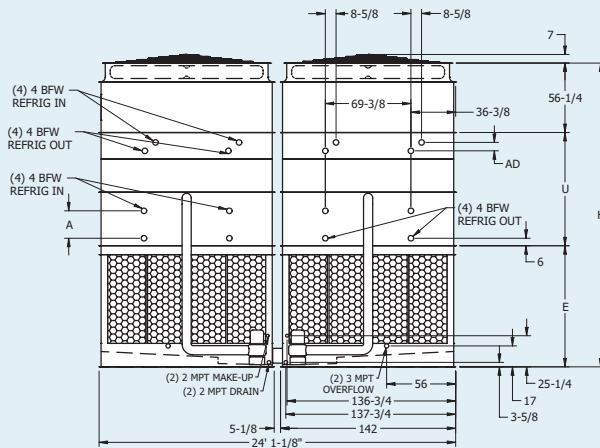

Table 22 Engineering Data

Model No.	R-717 Tons*		Fans		Weights†			Coil Volume (ft ³)	NH ₃ Op. Charge (lbs.)	Spray Pump		Remote Sump		Dimensions (ft)			Dimensions (in)		
	Wet Capacity	Dry Capacity @ 50°F DB Switch Point	HP	CFM	Shipping	Heaviest Section†	Operating			HP	GPM	Gallons Req'd**	Conn. Size	Operating Weight (lbs)	Height H	Lower E	Middle U	Wet Coil A	Dry Coil AD
eco-ATC-H 24-2K18-U22	646	509	2 20	202,700	50,750	17,780	68,130	102	681	2 7.5	2400	1440	2 12"	56,390	19' 9-7/8"	8' 2-1/4"	6' 11-3/8"	13-3/4"	5-1/2"
eco-ATC-H 24-2K18-U34	655	590	2 20	197,200	53,400	19,100	70,820	111	715	2 7.5	2400	1440	2 12"	59,080	19' 9-7/8"	8' 2-1/4"	6' 11-3/8"	13-3/4"	6-7/8"
eco-ATC-H 24-2L18-U22	679	533	2 25	216,100	50,810	17,780	68,190	102	681	2 7.5	2400	1440	2 12"	56,450	19' 9-7/8"	8' 2-1/4"	6' 11-3/8"	13-3/4"	5-1/2"
eco-ATC-H 24-2L18-U34	687	620	2 25	209,800	53,460	19,100	70,880	111	715	2 7.5	2400	1440	2 12"	59,140	19' 9-7/8"	8' 2-1/4"	6' 11-3/8"	13-3/4"	6-7/8"
eco-ATC-H 24-2M18-U22	707	554	2 30	227,600	50,910	17,780	68,290	102	681	2 7.5	2400	1440	2 12"	56,550	19' 9-7/8"	8' 2-1/4"	6' 11-3/8"	13-3/4"	5-1/2"
eco-ATC-H 24-2M18-U34	715	645	2 30	220,500	53,560	19,100	70,980	111	715	2 7.5	2400	1440	2 12"	59,240	19' 9-7/8"	8' 2-1/4"	6' 11-3/8"	13-3/4"	6-7/8"
eco-ATC-H 24-2N18-U22	752	582	2 40	243,800	51,230	17,780	68,610	102	681	2 7.5	2400	1440	2 12"	56,870	19' 9-7/8"	8' 2-1/4"	6' 11-3/8"	13-3/4"	5-1/2"
eco-ATC-H 24-2N18-U34	759	680	2 40	235,800	53,880	19,100	71,300	111	715	2 7.5	2400	1440	2 12"	59,560	19' 9-7/8"	8' 2-1/4"	6' 11-3/8"	13-3/4"	6-7/8"
eco-ATC-H 24-3K18-U22	757	538	2 20	201,200	60,210	22,510	77,890	141	970	2 7.5	2400	1440	2 12"	66,150	20' 6-3/8"	8' 2-1/4"	7' 7-7/8"	22-1/4"	5-1/2"
eco-ATC-H 24-3K18-U34	764	604	2 20	196,600	62,860	23,830	80,580	150	1004	2 7.5	2400	1440	2 12"	68,840	20' 6-3/8"	8' 2-1/4"	7' 7-7/8"	22-1/4"	6-7/8"
eco-ATC-H 24-3L18-U22	797	565	2 25	214,900	60,270	22,510	77,950	141	970	2 7.5	2400	1440	2 12"	66,210	20' 6-3/8"	8' 2-1/4"	7' 7-7/8"	22-1/4"	5-1/2"
eco-ATC-H 24-3L18-U34	803	636	2 25	209,500	62,920	23,830	80,640	150	1004	2 7.5	2400	1440	2 12"	68,900	20' 6-3/8"	8' 2-1/4"	7' 7-7/8"	22-1/4"	6-7/8"
eco-ATC-H 24-3M18-U22	831	588	2 30	226,600	60,370	22,510	78,050	141	970	2 7.5	2400	1440	2 12"	66,310	20' 6-3/8"	8' 2-1/4"	7' 7-7/8"	22-1/4"	5-1/2"
eco-ATC-H 24-3M18-U34	837	663	2 30	220,600	63,020	23,830	80,740	150	1004	2 7.5	2400	1440	2 12"	69,000	20' 6-3/8"	8' 2-1/4"	7' 7-7/8"	22-1/4"	6-7/8"
eco-ATC-H 24-3N18-U22	886	619	2 40	243,200	60,690	22,510	78,370	141	970	2 7.5	2400	1440	2 12"	66,630	20' 6-3/8"	8' 2-1/4"	7' 7-7/8"	22-1/4"	5-1/2"
eco-ATC-H 24-3N18-U34	890	701	2 40	236,300	63,340	23,830	81,060	150	1004	2 7.5	2400	1440	2 12"	69,320	20' 6-3/8"	8' 2-1/4"	7' 7-7/8"	22-1/4"	6-7/8"
eco-ATC-H 24-3O18-U22	930	643	2 50	256,600	60,710	22,510	78,390	141	970	2 7.5	2400	1440	2 12"	66,650	20' 6-3/8"	8' 2-1/4"	7' 7-7/8"	22-1/4"	5-1/2"
eco-ATC-H 24-3O18-U34	934	731	2 50	248,800	63,360	23,830	81,080	150	1004	2 7.5	2400	1440	2 12"	69,340	20' 6-3/8"	8' 2-1/4"	7' 7-7/8"	22-1/4"	6-7/8"
eco-ATC-H 24-4K18-U22	838	557	2 20	198,200	69,710	27,260	87,670	181	1,259	2 7.5	2400	1440	2 12"	75,930	21' 2-7/8"	8' 2-1/4"	8' 4-3/8"	30-3/4"	5-1/2"
eco-ATC-H 24-4K18-U34	843	609	2 20	194,300	72,360	28,580	90,360	190	1,293	2 7.5	2400	1440	2 12"	78,620	21' 2-7/8"	8' 2-1/4"	8' 4-3/8"	30-3/4"	6-7/8"
eco-ATC-H 24-4L18-U22	883	586	2 25	211,900	69,770	27,260	87,730	181	1,259	2 7.5	2400	1440	2 12"	75,990	21' 2-7/8"	8' 2-1/4"	8' 4-3/8"	30-3/4"	5-1/2"
eco-ATC-H 24-4L18-U34	888	644	2 25	207,400	72,420	28,580	90,420	190	1,293	2 7.5	2400	1440	2 12"	78,680	21' 2-7/8"	8' 2-1/4"	8' 4-3/8"	30-3/4"	6-7/8"
eco-ATC-H 24-4M18-U22	922	611	2 30	223,800	69,870	27,260	87,830	181	1,259	2 7.5	2400	1440	2 12"	76,090	21' 2-7/8"	8' 2-1/4"	8' 4-3/8"	30-3/4"	5-1/2"
eco-ATC-H 24-4M18-U34	926	673	2 30	218,700	72,520	28,580	90,520	190	1,293	2 7.5	2400	1440	2 12"	78,780	21' 2-7/8"	8' 2-1/4"	8' 4-3/8"	30-3/4"	6-7/8"
eco-ATC-H 24-4N18-U22	984	645	2 40	240,500	70,190	27,260	88,150	181	1,259	2 7.5	2400	1440	2 12"	76,410	21' 2-7/8"	8' 2-1/4"	8' 4-3/8"	30-3/4"	5-1/2"
eco-ATC-H 24-4N18-U34	987	713	2 40	234,600	72,840	28,580	90,840	190	1,293	2 7.5	2400	1440	2 12"	79,100	21' 2-7/8"	8' 2-1/4"	8' 4-3/8"	30-3/4"	6-7/8"
eco-ATC-H 24-4O18-U22	1,034	671	2 50	254,100	70,210	27,260	88,170	181	1,259	2 7.5	2400	1440	2 12"	76,430	21' 2-7/8"	8' 2-1/4"	8' 4-3/8"	30-3/4"	5-1/2"
eco-ATC-H 24-4O18-U34	1,036	745	2 50	247,300	72,860	28,580	90,860	190	1,293	2 7.5	2400	1440	2 12"	79,120	21' 2-7/8"	8' 2-1/4"	8' 4-3/8"	30-3/4"	6-7/8"

* Tons at standard conditions: 96.3°F condensing, 20°F suction and 78°F W.B.

** Gallons shown is water in suspension in unit and piping. Allow for additional water in bottom of remote sump to cover pump suction and strainer during operation. (12" would normally be sufficient.)

† Heaviest section is the coil section.

Dimensions are subject to change. Do not use for pre-fabrication. Quantity of coil connections subject to change based on refrigerant and design conditions.

NOTE: Interconnecting piping between ARID *fin Pak*™ Dry Coil outlets and Ellipti-*fin*® Coil inlets are field installed and tested (by others).

Engineering Dimensions & Data

eco-ATC-H 24-2L20-U22 to eco-ATC-H 24-4P20-U34

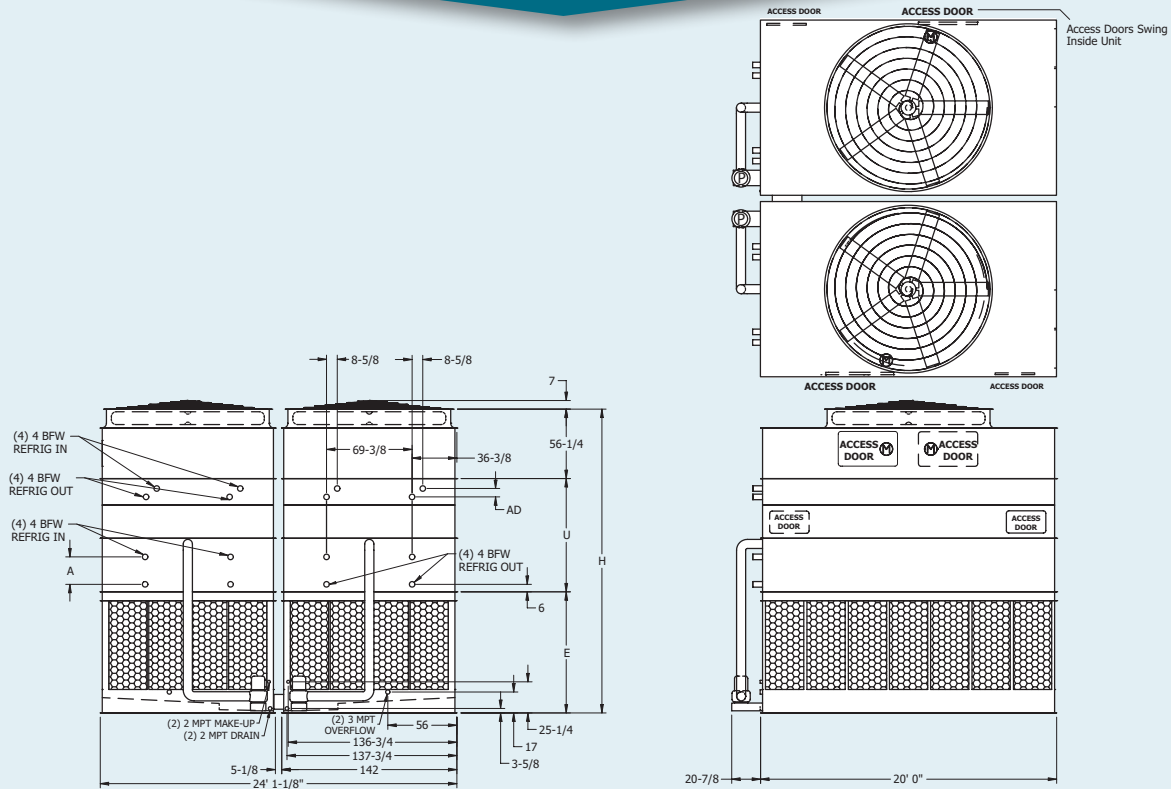

Table 23 Engineering Data

Model No.	R-717 Tons*		Fans		Weights†			Coil Volume (ft.)	NH3 Op. Charge (lbs.)	Spray Pump		Remote Sump			Dimensions (ft)			Dimensions (in)	
	Wet Capacity	Dry Capacity @ 50°F DB Switch Point	HP	CFM	Shipping	Heaviest Section†	Operating			HP	GPM	Gallons Req'd**	Conn. Size	Operating Weight (lbs)	Height H	Lower E	Middle U	Wet Coil A	Dry Coil AD
eco-ATC-H 24-2L20-U22	738	573	2 25	233,400	55,640	19,420	75,270	113	755	2 10	2800	1600	2 14"	61,870	19' 9-7/8"	8' 2-1/4"	6' 11-3/8"	13-3/4"	5-1/2"
eco-ATC-H 24-2L20-U34	748	671	2 25	226,900	58,590	20,900	78,270	123	792	2 10	2800	1600	2 14"	64,870	19' 9-7/8"	8' 2-1/4"	6' 11-3/8"	13-3/4"	6-7/8"
eco-ATC-H 24-2M20-U22	769	595	2 30	245,900	55,740	19,420	75,370	113	755	2 10	2800	1600	2 14"	61,970	19' 9-7/8"	8' 2-1/4"	6' 11-3/8"	13-3/4"	5-1/2"
eco-ATC-H 24-2M20-U34	778	698	2 30	238,600	58,690	20,900	78,370	123	792	2 10	2800	1600	2 14"	64,970	19' 9-7/8"	8' 2-1/4"	6' 11-3/8"	13-3/4"	6-7/8"
eco-ATC-H 24-2N20-U22	818	629	2 40	264,800	56,060	19,420	75,690	113	755	2 10	2800	1600	2 14"	62,290	19' 9-7/8"	8' 2-1/4"	6' 11-3/8"	13-3/4"	5-1/2"
eco-ATC-H 24-2N20-U34	827	739	2 40	256,400	59,010	20,900	78,690	123	792	2 10	2800	1600	2 14"	65,290	19' 9-7/8"	8' 2-1/4"	6' 11-3/8"	13-3/4"	6-7/8"
eco-ATC-H 24-2O20-U22	858	653	2 50	279,000	56,080	19,420	75,710	113	755	2 10	2800	1600	2 14"	62,310	19' 9-7/8"	8' 2-1/4"	6' 11-3/8"	13-3/4"	5-1/2"
eco-ATC-H 24-2O20-U34	867	770	2 50	269,700	59,030	20,900	78,710	123	792	2 10	2800	1600	2 14"	65,310	19' 9-7/8"	8' 2-1/4"	6' 11-3/8"	13-3/4"	6-7/8"
eco-ATC-H 24-3L20-U22	866	605	2 25	231,800	66,320	24,760	86,270	157	1,077	2 10	2800	1600	2 14"	72,870	20' 6-3/8"	8' 2-1/4"	7' 7-7/8"	22-1/4"	5-1/2"
eco-ATC-H 24-3L20-U34	873	687	2 25	226,400	69,270	26,240	89,270	167	1,113	2 10	2800	1600	2 14"	75,870	20' 6-3/8"	8' 2-1/4"	7' 7-7/8"	22-1/4"	6-7/8"
eco-ATC-H 24-3M20-U22	903	629	2 30	244,600	66,420	24,760	86,370	157	1,077	2 10	2800	1600	2 14"	72,970	20' 6-3/8"	8' 2-1/4"	7' 7-7/8"	22-1/4"	5-1/2"
eco-ATC-H 24-3M20-U34	910	717	2 30	238,400	69,370	26,240	89,370	167	1,113	2 10	2800	1600	2 14"	75,970	20' 6-3/8"	8' 2-1/4"	7' 7-7/8"	22-1/4"	6-7/8"
eco-ATC-H 24-3N20-U22	963	665	2 40	263,900	66,740	24,760	86,690	157	1,077	2 10	2800	1600	2 14"	73,290	20' 6-3/8"	8' 2-1/4"	7' 7-7/8"	22-1/4"	5-1/2"
eco-ATC-H 24-3N20-U34	969	760	2 40	256,700	69,690	26,240	89,690	167	1,113	2 10	2800	1600	2 14"	76,290	20' 6-3/8"	8' 2-1/4"	7' 7-7/8"	22-1/4"	6-7/8"
eco-ATC-H 24-3O20-U22	1,011	692	2 50	278,500	66,760	24,760	86,710	157	1,077	2 10	2800	1600	2 14"	73,310	20' 6-3/8"	8' 2-1/4"	7' 7-7/8"	22-1/4"	5-1/2"
eco-ATC-H 24-3O20-U34	1,017	793	2 50	270,400	69,710	26,240	89,710	167	1,113	2 10	2800	1600	2 14"	76,310	20' 6-3/8"	8' 2-1/4"	7' 7-7/8"	22-1/4"	6-7/8"
eco-ATC-H 24-3P20-U22	1,053	714	2 60	290,900	67,160	24,760	87,110	157	1,077	2 10	2800	1600	2 14"	73,710	20' 6-3/8"	8' 2-1/4"	7' 7-7/8"	22-1/4"	5-1/2"
eco-ATC-H 24-3P20-U34	1,057	820	2 60	282,100	70,110	26,240	90,110	167	1,113	2 10	2800	1600	2 14"	76,710	20' 6-3/8"	8' 2-1/4"	7' 7-7/8"	22-1/4"	6-7/8"
eco-ATC-H 24-4L20-U22	959	626	2 25	228,500	76,800	30,000	97,070	201	1,398	2 10	2800	1600	2 14"	83,670	21' 2-7/8"	8' 2-1/4"	8' 4-3/8"	30-3/4"	5-1/2"
eco-ATC-H 24-4L20-U34	964	694	2 25	223,900	79,750	31,480	100,070	211	1,435	2 10	2800	1600	2 14"	86,670	21' 2-7/8"	8' 2-1/4"	8' 4-3/8"	30-3/4"	6-7/8"
eco-ATC-H 24-4M20-U22	1,001	652	2 30	241,300	76,900	30,000	97,170	201	1,398	2 10	2800	1600	2 14"	83,770	21' 2-7/8"	8' 2-1/4"	8' 4-3/8"	30-3/4"	5-1/2"
eco-ATC-H 24-4M20-U34	1,006	725	2 30	236,100	79,850	31,480	100,170	211	1,435	2 10	2800	1600	2 14"	86,770	21' 2-7/8"	8' 2-1/4"	8' 4-3/8"	30-3/4"	6-7/8"
eco-ATC-H 24-4N20-U22	1,069	691	2 40	260,800	77,220	30,000	97,490	201	1,398	2 10	2800	1600	2 14"	84,090	21' 2-7/8"	8' 2-1/4"	8' 4-3/8"	30-3/4"	5-1/2"
eco-ATC-H 24-4N20-U34	1,073	772	2 40	254,600	80,170	31,480	100,490	211	1,435	2 10	2800	1600	2 14"	87,090	21' 2-7/8"	8' 2-1/4"	8' 4-3/8"	30-3/4"	6-7/8"
eco-ATC-H 24-4O20-U22	1,124	720	2 50	275,600	77,240	30,000	97,510	201	1,398	2 10	2800	1600	2 14"	84,110	21' 2-7/8"	8' 2-1/4"	8' 4-3/8"	30-3/4"	5-1/2"
eco-ATC-H 24-4O20-U34	1,127	806	2 50	268,600	80,190	31,480	100,510	211	1,435	2 10	2800	1600	2 14"	87,110	21' 2-7/8"	8' 2-1/4"	8' 4-3/8"	30-3/4"	6-7/8"
eco-ATC-H 24-4P20-U22	1,171	744	2 60	288,100	77,640	30,000	97,910	201	1,398	2 10	2800	1600	2 14"	84,510	21' 2-7/8"	8' 2-1/4"	8' 4-3/8"	30-3/4"	5-1/2"
eco-ATC-H 24-4P20-U34	1,173	835	2 60	280,400	80,590	31,480	100,910	211	1,435	2 10	2800	1600	2 14"	87,510	21' 2-7/8"	8' 2-1/4"	8' 4-3/8"	30-3/4"	6-7/8"

* Tons at standard conditions: 96.3°F condensing, 20°F suction and 78°F W.B.

** Gallons shown is water in suspension in unit and piping. Allow for additional water in bottom of remote sump to cover pump suction and strainer during operation. (12" would normally be sufficient.)

† Heaviest section is the coil section.

Dimensions are subject to change. Do not use for pre-fabrication. Quantity of coil connections subject to change based on refrigerant and design conditions.

NOTE: Interconnecting piping between ARID fin Pak™ Dry Coil outlets and Ellipti-fin® Coil inlets are field installed and tested (by others).

eco-ATC-H Steel Support

EVAPCO eco-ATC-H condensers are designed to be supported with structural "I" beams located under the outer flanges and running the entire length of the unit. Mounting holes, 3/4" in diameter are located in the bottom channels of the pan section to provide for bolting to the structural steel. (Refer to certified drawings from the factory for bolt hole locations.)

Beams should be level to within 1/8" in 6' before setting the unit in place. Do not level the unit by shimming between it and the "I" beams as this will not provide proper longitudinal support.

NOTE: Consult IBC for required steel support layout and structural design.

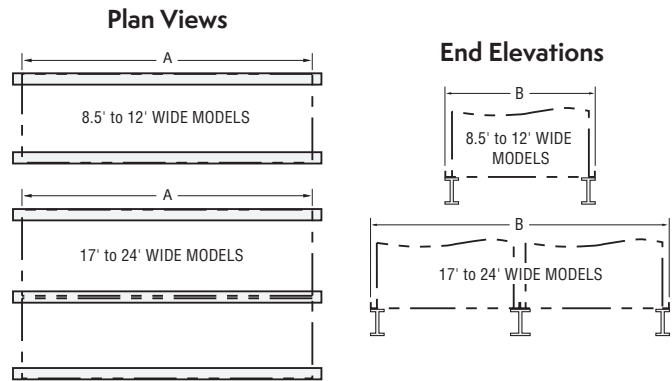

eco-ATC-H Steel Support		
8-1/2' Wide Models	A	B
eco-ATC-H 9-2H9-U22 to eco-ATC-H 9-4K9-U34	8' 11-1/2"	8' 5-1/2"
eco-ATC-H 9-2H12-U22 to eco-ATC-H 9-4M12-U34	11' 11-3/4"	8' 5-1/2"
eco-ATC-H 9-2H14-U22 to eco-ATC-H 9-4M14-U34	13' 11-3/4"	8' 5-1/2"
eco-ATC-H 9-2H18-U22 to eco-ATC-H 9-4K18-U34	18'	8' 5-1/2"
eco-ATC-H 9-2H21-U22 to eco-ATC-H 9-4L21-U34	21'	8' 5-1/2"
17' Wide Models	A	B
eco-ATC-H 17-2H12-U22 to eco-ATC-H 17-4M12-U34	11' 11-3/4"	17' 4-1/8"
eco-ATC-H 17-2H14-U22 to eco-ATC-H 17-4M14-U34	13' 11-3/4"	17' 4-1/8"
10' Wide Models	A	B
eco-ATC-H 10-2H12-U22 to eco-ATC-H 10-4M12-U34	11' 11-3/4"	9' 9-3/4"
eco-ATC-H 10-2H18-U22 to eco-ATC-H 10-4N18-U34	18'	9' 9-3/4"
eco-ATC-H 10-2H24-U22 to eco-ATC-H 10-4M24-U34	24' 2"	9' 9-3/4"
eco-ATC-H 10-2H36-U22 to eco-ATC-H 10-4N36-U34	36' 2-1/2"	9' 9-3/4"
12' Wide Models	A	B
eco-ATC-H 12-2H12-U22 to eco-ATC-H 12-4N12-U34	11' 11-3/4"	11' 10"
eco-ATC-H 12-2K14-U22 to eco-ATC-H 12-4N14-U34	13' 11-3/4"	11' 10"
eco-ATC-H 12-2K18-U22 to eco-ATC-H 12-4O18-U34	18'	11' 10"
eco-ATC-H 12-2L20-U22 to eco-ATC-H 12-4P20-U34	20'	11' 10"
eco-ATC-H 12-2J24-U22 to eco-ATC-H 12-4N24-U34	24' 2"	11' 10"
eco-ATC-H 12-2K28-U22 to eco-ATC-H 12-4N28-U34	28' 2"	11' 10"
eco-ATC-H 12-2K36-U22 to eco-ATC-H 12-4O36-U34	36' 2-1/2"	11' 10"
eco-ATC-H 12-2L40-U22 to eco-ATC-H 12-4P40-U34	40' 2-1/2"	11' 10"
24' Wide Models	A	B
eco-ATC-H 24-2H12-U22 to eco-ATC-H 24-4N12-U34	11' 11-3/4"	24' 1-1/8"
eco-ATC-H 24-2K14-U22 to eco-ATC-H 24-4N14-U34	13' 11-3/4"	24' 1-1/8"
eco-ATC-H 24-2K18-U22 to eco-ATC-H 24-4O18-U34	18'	24' 1-1/8"
eco-ATC-H 24-2L20-U22 to eco-ATC-H 24-4P20-U34	20'	24' 1-1/8"

eco-ATC-H Optional Equipment

Electric Heaters

Electric immersion heaters are available factory installed in the basin of the condenser. They are sized to maintain a +40° F pan water temperature with the fans off and an ambient air temperature of 0°F, -20°F or -40°F. They are furnished with a thermostat to cycle the heater on when required and a low water protection device to prevent the heater elements from energizing unless they are completely submerged. All components are in weather proof enclosures for outdoor use. The heater power contactors and electric wiring are not included as standard.

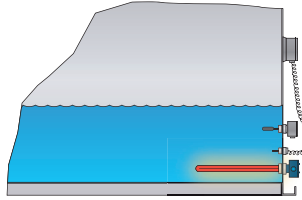

ATC-DC Heater Sizes (kW)			
8-1/2' Wide Models	0°F	-20°F	-40°F
eco-ATC-H 9-2H9-U22 to eco-ATC-H 9-4K9-U34	7	10	15
eco-ATC-H 9-2I12-U22 to eco-ATC-H 9-4M12-U34	(2) 4	(2) 7	(2) 9
eco-ATC-H 9-2I14-U22 to eco-ATC-H 9-4M14-U34	(2) 5	(2) 7	(2) 10
eco-ATC-H 9-2H18-U22 to eco-ATC-H 9-4K18-U34	(2) 6	(2) 9	(2) 12
eco-ATC-H 9-2H21-U22 to eco-ATC-H 9-4L21-U34	(2) 7	(2) 12	(2) 15
17' Wide Models	0°F	-20°F	-40°F
eco-ATC-H 17-2I12-U22 to eco-ATC-H 17-4M12-U34	(4) 4	(4) 7	(4) 9
eco-ATC-H 17-2I14-U22 to eco-ATC-H 17-4M14-U34	(4) 5	(4) 7	(4) 10
10' Wide Models	0°F	-20°F	-40°F
eco-ATC-H 10-2I12-U22 to eco-ATC-H 10-4M12-U34	(2) 5	(2) 8	(2) 10
eco-ATC-H 10-2I18-U22 to eco-ATC-H 10-4N18-U34	(2) 7	(2) 12	(2) 15
eco-ATC-H 10-2I24-U22 to eco-ATC-H 10-4M24-U34	(4) 5	(4) 8	(4) 10
eco-ATC-H 10-2I36-U22 to eco-ATC-H 10-4N36-U34	(4) 7	(4) 12	(4) 15
12' Wide Models	0°F	-20°F	-40°F
eco-ATC-H 12-2I12-U22 to eco-ATC-H 12-4N12-U34	(2) 6	(2) 9	(2) 12
eco-ATC-H 12-2K14-U22 to eco-ATC-H 12-4N14-U34	(2) 7	(2) 10	(2) 15
eco-ATC-H 12-2K18-U22 to eco-ATC-H 12-4O18-U34	(2) 9	(2) 15	(2) 18
eco-ATC-H 12-2L20-U22 to eco-ATC-H 12-4P20-U34	(2) 10	(2) 15	(3) 15
eco-ATC-H 12-2J24-U22 to eco-ATC-H 12-4N24-U34	(4) 6	(4) 9	(4) 12
eco-ATC-H 12-2K28-U22 to eco-ATC-H 12-4N28-U34	(4) 7	(4) 10	(4) 15
eco-ATC-H 12-2K36-U22 to eco-ATC-H 12-4O36-U34	(4) 9	(4) 15	(4) 18
eco-ATC-H 12-2L40-U22 to eco-ATC-H 12-4P40-U34	(4) 10	(4) 15	(6) 15
24' Wide Models	0°F	-20°F	-40°F
eco-ATC-H 24-2J12-U22 to eco-ATC-H 24-4N12-U34	(4) 6	(4) 9	(4) 12
eco-ATC-H 24-2K14-U22 to eco-ATC-H 24-4N14-U34	(4) 7	(4) 10	(4) 15
eco-ATC-H 24-2K18-U22 to eco-ATC-H 24-4O18-U34	(4) 9	(4) 15	(4) 18
eco-ATC-H 24-2L20-U22 to eco-ATC-H 24-4P20-U34	(4) 10	(4) 15	(4) 20

Water Treatment Solutions

Pulse~Pure® Non-Chemical Treatment

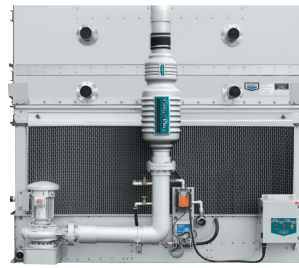

U.S. Patent No. 7,704,364

Pulse~Pure® is an environmentally sensitive non-chemical water treatment system for evaporative condensers. Developed by EVAPCO, Pulse~Pure offers an alternative to chemical water treatment programs. Utilizing pulse-power technology Pulse~Pure provides chemical-free treatment that is environmentally safe.

Smart Shield® Solid Chemistry Water Treatment System

EVAPCO's SmartShield® solid chemistry water treatment system is an innovative solution to conventional liquid chemical programs. SmartShield® was developed specifically for evaporative condensers and closed circuit coolers. The system comes factory mounted and includes all the components required for an effective water treatment system. Solid products eliminate the potential for liquid spills making it easier and safer to use. Controlled release chemistry provides uniform treatment over a 30 day period.



Self Supporting Service Platforms

Condensers are available with self-supporting service platforms that include access ladders which are designed for easy field installation. This option offers significant savings in comparison to field constructed, externally supported catwalks. The Evapco service platform option is located at each maintenance access door.

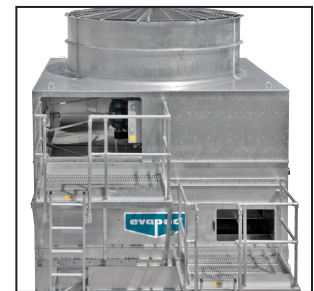

ATC-DC Condenser with Optional Service Platforms

Motor Davit

In the event that a fan motor should need to be replaced, a lightweight motor davit is available from which a chain fall can be mounted to easily lower the motor to the ground.

eco-ATC-H Optional Equipment

Electric Water Level Control

Evaporative condensers may be ordered with an electric water level control in lieu of the standard mechanical float and make-up assembly. This package provides accurate control of water levels and does not require field adjustment.



Sound Reduction Options

Super-Low Sound Fan

EVAPCO's Super Low Sound Fan utilizes an extremely wide chord blade design and is ideal for low energy, sound sensitive installations without sacrificing thermal performance. This revolutionary technology is one-piece molded, heavy duty fiberglass reinforced polyester hub and blade construction utilizing a forward swept blade design. The Super Low Sound Fan is capable of reducing the unit sound pressure levels 9 dB(A) to 15 dB(A) depending on specific unit selection and measurement location.

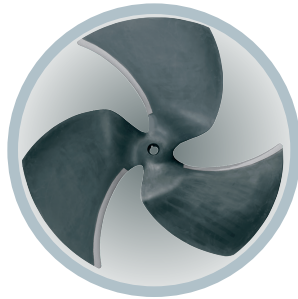

Water Silencer

The water silencer option, constructed of lightweight PVC sections, is located in the falling water area of the cold water basin. This option will reduce the overall sound levels 4 dB(A) to 7 dB(A), measured 5 ft. from the side or end of the unit, with no impact on unit thermal performance. This option will also reduce the overall sound levels 9 dB(A) to 12 dB(A) when operating the condenser with the fans off and water circulating.

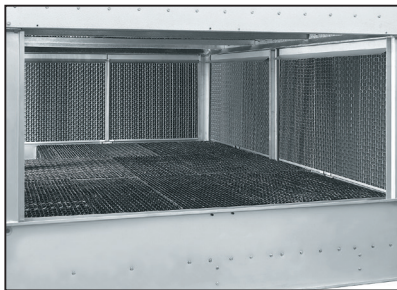

Stainless Steel Basin

In addition to the EVAPCOAT Corrosion Protection System, EVAPCO offers optional Type 304 or Type 316 stainless steel construction for superior corrosion resistance. EVAPCO induced draft condensers have a modular design which allows for specific areas to be enhanced for increased corrosion protection. The basin area of a condenser is often subjected to high concentrations of impurities and silt. EVAPCO's stainless steel basin option includes welded seam construction as standard. For particularly corrosive environments, stainless steel construction is also available for the coil casing/fan section.

Remote Sump Configuration

For units operating in areas where temperatures may be very low, or where low temperatures may occur during periods when the unit is not operating, a sump located inside the building is the preferred means of ensuring that the basin water will not freeze. For these applications, the condenser will be supplied without the spray pump, suction strainers and all associated piping, but with an oversize bottom outlet.

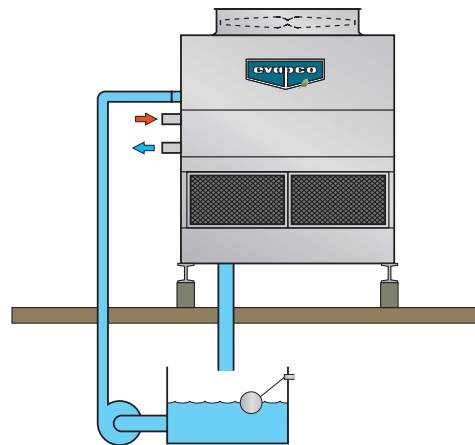

Multiple Circuit Coils

Condensers may be supplied with multiple circuit coils to match various system requirements such as split systems, or if a glycol or water circuit is desired for compressor head cooling.

Additional Options Available – Please contact your local EVAPCO Sales Representative or the EVAPCO factory for assistance.

eco-ATC-H Application

Design

EVAPCO units are heavy-duty construction and designed for long trouble-free operation. Proper equipment selection, installation and maintenance is, however, necessary to ensure good unit performance. Some of the major considerations in the application of a condenser are presented below. For additional information, contact the factory.

Structural Steel Support

The method of support for EVAPCO condensers is two structural "I" beams located under the outer flanges and running the entire length of the unit. Mounting holes 3/4" in diameter, are located in the bottom channels of the pan section to provide for bolting to the structural steel; refer to certified drawings from the factory for bolt hole locations.

Beams should be level to within 1/8" in 6' before setting the unit in place. Do not level the unit by shimming between it and the "I" beams as this will not provide proper longitudinal support.

NOTE: Consult IBC for required steel support layout and structural design.

Air Circulation

In reviewing the system design and unit location, it is important that proper air circulation be provided. The best location is on an unobstructed roof top or on ground level away from walls and other barriers. Care must be taken when locating condensers in wells or enclosures or next to high walls. The potential for recirculation of hot, moist discharge air back into the fan intake exists. Recirculation raises the wet bulb temperature of the entering air causing the condensing pressure to rise above the design. For these cases, a discharge hood or ductwork should be provided to raise the overall unit height even with the adjacent wall, thereby reducing the chance of recirculation. Good engineering practice dictates that the evaporative condenser's discharge air not be directed or located close to or in the vicinity of building air intakes. Engineering assistance is available from the factory to identify potential recirculation problems and recommend solutions.

For additional information regarding layout of evaporative condensers, see EVAPCO Bulletin entitled "*Equipment Layout*".

Piping

Condenser piping should be designed and installed in accordance with generally accepted engineering practice. All piping should be anchored by properly designed hangers and supports with allowance made for possible expansion and contraction. No external loads should be placed upon condenser connections, nor should any of the pipe supports be anchored to the unit framework. For additional information concerning refrigerant pipe sizing and layout, see EVAPCO Bulletin entitled "*Piping Evaporative Condensers*".

Maintaining the Recirculated Water System

The heat rejection in a condenser is accomplished by the evaporation of a portion of the recirculated spray water. As this water evaporates, it leaves behind all of its mineral content and impurities. Therefore, it is important to bleed-off an amount of water equal to that which is evaporated to prevent the build-up of these impurities. If this is not done, the mineral or the acidic nature of the water will continue to increase. This will ultimately result in heavy scaling or a corrosive condition.

Bleed-off

Each unit supplied with a pump mounted on the side is furnished with a clear bleed line for visual inspection and a valve which, when fully open, will bleed-off the proper amount of water. If the make-up water supplying the unit is relatively free of impurities, it may be possible to cut back the bleed, but the unit must be checked frequently to make sure scale is not forming. Make-up water pressure should be maintained between 20 and 50 psig.

Water Treatment

A proper water treatment program is an essential part of routine maintenance in order to help assure proper operation and longevity of the unit. To help prevent the formation of "white rust", the interior of the unit should be passivated during start-up and monitored periodically as part of the water treatment program. For more information about white rust, please request a copy of EVAPCO Engineering Bulletin 36. A qualified water treatment company should be contacted to design a water treatment protocol specifically based on applicable location, water quality and unit materials of construction.

If acid is used for treatment, it should be accurately metered and the concentration properly controlled. **The pH of the water should be maintained between 6.5 and 8.0. Units constructed of galvanized steel operating with circulating water having a pH of 8.3 or higher will require periodic passivation of the galvanized steel to prevent the formation of "white rust"**. Batch chemical feeding is not recommended because it does not afford the proper degree of control. If acid cleaning is required extreme caution must be exercised and only inhibited acids recommended for use with galvanized construction should be used.

NOTE: Operating the condenser below 6.0 pH for any period of time may cause the removal of the protective zinc coating on the galvanized steel components.

For more information see EVAPCO Bulletin entitled "*Maintenance Instructions*".

Control of Biological Contamination

Water quality should be checked regularly for biological contamination. If biological contamination is detected, a more aggressive water treatment and mechanical cleaning program should be undertaken. The water treatment program should be performed in conjunction with a qualified water treatment company. It is important that all internal surfaces be kept clean of accumulated dirt and sludge. In addition, the drift eliminators should be maintained in good operating condition.

Solutions for Sound Sensitive Applications

The eco-ATC-H product line is available with four (4) equipment options to reduce the overall sound generated from the side or top of the unit. Each option provides various levels of sound reduction and can be used in combination to provide the lowest sound level. Consult EVAPCO's *evapSelect*® selection program for unit sound levels. If a detailed analysis or full octave band data sheet is required for your application, please consult your EVAPCO Sales Representative.

NOTE: These low sound options may impact the overall installed dimensions and weight of the unit.

eco-ATC-H Mechanical Specifications

Furnish and install, as shown on the plans, an EVAPCO model _____ induced draft, counterflow evaporative condenser with a condensing capacity of _____ MBH total heat of rejection when operating with _____ refrigerant at _____ °F condensing temperature at a design _____ ambient dry bulb temperature of _____ °F.

IBC Compliance

The condenser shall be designed and constructed to meet the International Building Code (IBC) specifications for installed components per ASCE. The manufacturer shall provide a certificate of compliance to demonstrate that the equipment/unit has been independently tested and certified in accordance with the IBC.

Basin and Casing

The basin and casing shall be constructed of G-235 hot-dip galvanized steel for long life and durability. Standard basin accessories shall include overflow, drain, type 304 stainless steel strainers, and brass make-up valve with plastic float.

Models eco-ATC-H 9-2H9-U22 to eco-ATC-H 17-4M14-U34

Fan Motor

_____horsepower totally enclosed fan cooled motors with 1.15 service factor shall be furnished suitable for outdoor service on _____volts, _____hertz, and _____phase.

Motor(s) shall be mounted on an adjustable base which is accessible from the outside of the unit for service. A swing away protective cover shall shield the motor and sheave from the weather.

Drive

The fan drive shall be multigroove, solid back V-belt type with taper lock bushings designed for 150% of the motor nameplate horsepower. The belt material shall be neoprene reinforced with polyester cord and specifically designed for evaporative condenser service. Fan sheave shall be aluminum alloy construction. The fans and the fan sheaves shall be mounted on the shaft with a specially coated bushing to provide maximum corrosion protection. Belt adjustment shall be accomplished from the exterior of the unit. Bearing lube lines shall be extended to the exterior of the unit for easy maintenance.

Models eco-ATC-H 10-2I12-U22 to eco-ATC-H 24-4P20-U34

Fan Motor

_____horsepower totally enclosed air over ball bearing fan motor(s), with 1.15 service factor shall be furnished suitable for service on _____volts, _____hertz, and _____phase.

Motor(s) shall be mounted on an adjustable base which allows the motor to swing to the outside of the unit for servicing.

Drive

The fan drive shall be a multigroove, solid back V-belt type with taper lock bushings designed for 150% of the motor nameplate horsepower. The belt material shall be neoprene reinforced with polyester cord and specifically designed for evaporative condenser service. Fan and motor sheaves shall be aluminum alloy construction. The fans and fan sheaves shall be mounted on the shaft with a specially coated bushing to provide maximum corrosion protection. Belt adjustment shall be accomplished from the exterior of the unit. Bearing lube lines shall be extended to the exterior of the unit for easy maintenance.

Axial Propeller Fans

Fans shall be heavy duty axial propeller type statically balanced. The fans shall be constructed of aluminum alloy or fiberglass reinforced polypropylene blades, installed in a closely fitted cowl with venturi air inlet. Fan screens shall be galvanized steel mesh and frame, bolted to the fan cowl.

Fan Shaft Bearings

Fan shaft bearings shall be heavy duty self-aligning ball type with grease fittings extended to the outside of the unit. Bearings shall be designed for a minimum L-10 life of 75,000 hours.

Water Recirculation Pump

The pump(s) shall be a close-coupled, centrifugal type with mechanical seal, installed vertically at the factory to allow free drainage on shut down. _____horsepower totally enclosed motor(s) shall be furnished suitable for outdoor service on _____volts, _____hertz, and _____phase.

Heat Transfer Coils

Dry Coil

Arid-fin Pak dry cooling coils shall be constructed of 5/8" diameter Type 304L Stainless Steel round tubing with carbon steel connections. Fins shall be marine grade aluminum with a fin density of 10 fins per inch. Tubing shall be hydraulically expanded into the fin plate for consistent contact. Coil shall have design pressure of 300 psi and shall be in compliance with ANSI/ASME B31.5, Refrigeration Piping and Heat Transfer Components. The coil assembly shall be strength tested in accordance with ANSI/ASME B31.5 and subsequently leak tested using air under water.

Wet Coil

Ellipti-fin condensing coil shall be elliptical tubes of prime surface steel, encased in steel framework with entire assembly hot-dip galvanized after fabrication. All coil rows shall feature extended surface fins designed with sloping tubes for liquid drainage. Coil shall have design pressure of 300 psi and shall be in compliance with ANSI/ASME B31.5, Refrigeration Piping and Heat Transfer Components. The coil assembly shall be strength tested in accordance with ANSI/ASME B31.5 and subsequently leak tested using air under water.

Water Distribution System

The system shall provide a water flow rate of 6 GPM over each square foot of unit face area to ensure proper flooding of the coil. The spray header shall be constructed of schedule 40 polyvinyl chloride pipe for corrosion resistance. All spray branches shall be removable for cleaning. Heavy-duty ABS spray nozzles with large 1-1/4" diameter opening and internal sludge ring to eliminate clogging. Nozzles shall be threaded into spray header to provide easy removal for maintenance.

Eliminators

The eliminators shall be constructed entirely of inert polyvinyl chloride (PVC) in easily handled sections. The eliminator design shall incorporate three changes in air direction to assure complete removal of all entrained moisture from the discharge air stream. Maximum drift rate shall be less than 0.001% of the circulating water rate.

Louvers

The louvers shall be constructed from polyvinyl chloride (PVC) and mounted in a rugged steel frame. The louvers shall be mounted in easily removable sections for access to the pan for maintenance. The louvers shall have a minimum of two changes in air direction to prevent splashout and block direct sunlight.

Finish

All basin and casing materials shall be constructed of G-235 heavy gauge mill hot-dip galvanized steel. During fabrication, all panel edges shall be coated with a 95% pure zinc-rich compound for superior protection against corrosion.



OUR PRODUCTS ARE MANUFACTURED WORLDWIDE.



★ World Headquarters/ Research and Development Center
■ EVAPCO Facilities



EVAPCO, Inc. — World Headquarters & Research / Development Center

P.O. Box 1300 • Westminster, MD 21158 USA
410-756-2600 • marketing@evapco.com • evapco.com

North America

EVAPCO, Inc.
World Headquarters
Westminster, MD USA
410.756.2600
marketing@evapco.com

EVAPCO East
Taneytown, MD USA
410.756.2600
marketing@evapco.com

EVAPCO East
Key Building
Taneytown, MD USA
410.756.2600
marketing@evapco.com

EVAPCO Midwest
Greenup, IL USA
217.923.3431
evapcomw@evapcomw.com

EVAPCO West
Madera, CA USA
559.673.2207
contact@evapcowest.com

EVAPCO Iowa
Lake View, IA USA
712.657.3223

EVAPCO Iowa
Sales & Engineering
Medford, MN USA
507.446.8005
evapcomn@evapcomn.com

EVAPCO Newton
Newton, IL USA
618.783.3433
evapcomw@evapcomw.com

Bulletin 170A
2M/10-20/DGD

Evapcold Manufacturing
Greenup, IL USA
217.923.3431
evapcomw@evapcomw.com

EVAPCO Dry Cooling, Inc.
Bridgewater, NJ USA
908.379.2665
info@evapcodc.com

EVAPCO Dry Cooling, Inc.
Littleton, CO USA
908.379.2665
info@evapcodc.com
Spare Parts: 908.895.3236
Spare Parts: spares@evapcodc.com

EVAPCO Power México S. de R.L. de C.V.
Mexico City, Mexico
(52) 55.8421.9260
info@evapcodc.com

Refrigeration Vessels & Systems Corporation
A wholly owned subsidiary of EVAPCO, Inc.
Bryan, TX USA
979.778.0095
rvs@rvscorp.com

EvapTech, Inc.
A wholly owned subsidiary of EVAPCO, Inc.
Edwardsville, KS USA
913.322.5165
marketing@evaptech.com

Tower Components, Inc.
A wholly owned subsidiary of EVAPCO, Inc.
Rameur, NC USA
336.824.2102
mail@towercomponentsinc.com

EVAPCO Alcoil, Inc.
A wholly owned subsidiary of EVAPCO, Inc.
York, PA USA
717.347.7500
info@evapco-alcoil.com

Europe

EVAPCO Europe BVBA
European Headquarters
Tongeren, Belgium
(32) 12.39.50.29
evapco.europe@evapco.be

EVAPCO Europe, S.r.l.
Milan, Italy
(39) 02.939.9041
evapcoeuropa@evapco.it

EVAPCO Europe, S.r.l.
Sondrio, Italy

EVAPCO Europe GmbH
Meerbusch, Germany
(49) 2159.69560
info@evapco.de

EVAPCO Air Solutions
A wholly owned subsidiary of EVAPCO, Inc.
Aabybro, Denmark
(45) 9824.4999
info@evapco.dk

EVAPCO Air Solutions GmbH
Garbsen, Germany
(49) 5137.938750
info@evapcoas.de

Evap Egypt Engineering Industries Co.
A licensed manufacturer of EVAPCO, Inc.
Nasr City, Cairo, Egypt
(202) 24044997 / (202) 24044998
mmanz@tiba-group.com /
hany@tiba-group.com

EVAPCO Middle East DMCC
Dubai, United Arab Emirates
(971) 4.448.7242
info@evapco.ae

EVAPCO S.A. (Pty.) Ltd.
A licensed manufacturer of EVAPCO, Inc.
Isando, South Africa
(27) 11.392.6630
evapco@evapco.co.za

Asia Pacific

EVAPCO Asia Pacific
Headquarters
Baoshan Industrial Zone
Shanghai, P.R. China
(86) 21.6687.7786
marketing@evapcochina.com

EVAPCO (Shanghai) Refrigeration Equipment Co., Ltd.
Baoshan Industrial Zone, Shanghai, P.R. China
(86) 21.6687.7786
marketing@evapcochina.com

EVAPCO (Beijing) Refrigeration Equipment Co., Ltd.
Huairou District, Beijing, P.R. China
(86) 10.6166.7238
marketing@evapcochina.com

EVAPCO Air Cooling Systems (Jiaxing) Company, Ltd.
Jiaxing, Zhejiang, China
(86) 573.8311.9379
info@evapcochina.com

EVAPCO Australia (Pty.) Ltd.
Riverstone, NSW, Australia
(61) 02.9627.3322
sales@evapco.com.au

EvapTech Asia Pacific Sdn. Bhd
A wholly owned subsidiary of EvapTech, Inc.
Puchong, Selangor, Malaysia
(60) 3.8070.7255
marketing-ap@evaptech.com

South America

EVAPCO Brasil
Equipamentos Industriais Ltda.
Indaiatuba, São Paulo, Brazil
(55) 11.5681.2000
vendas@evapco.com.br

FanTR Technology Resources
Indaiatuba, São Paulo, Brazil
(55) 11.4025.1670
fantr@fantr.com

©2020 EVAPCO, Inc.

Committed to making life easier, more reliable and more sustainable for people everywhere